

# CLP0112 Open Frame Power Supply

**90 - 265V<sub>ac</sub> input; 12V<sub>dc</sub> output; 150W Output Power**



In a small 2 x 4 inch footprint, the 12V<sub>dc</sub> single-output CLP0112 open frame power supply delivers greater than 90 percent typical power efficiency and full load output at 75°C. With its small size, the CLP series is specifically designed to handle power challenges associated with tight space and low airflow. The CLP series utilizes a unique design approach at this power level, leveraging zero voltage switching techniques in conjunction with quasi-resonant power factor correction (PFC) circuits. Protection features include overcurrent (OCP), overvoltage (OVP), and overtemperature (OTP).

## Applications

- Telecommunications equipment
- Embedded Computing
- Storage Systems
- Industrial equipment

## Features

- Compact size 50.8 mm x 101.6 mm x 36.1 mm (2 in x 4 in x 1.4 in) with density of 13.4W/in<sup>3</sup>
- Universal AC Input Range (90 – 265V<sub>AC</sub>)
- Output voltage of 12V (adjustable -2.5/+5%)
- Maximum output current of 12.5A@ 12V<sub>out</sub> (150W)
- High efficiency
- Full load capability at 75°C and 1m/s (200LFM) airflow with derating at higher temperatures or lower airflows
- When used inside sealed enclosure, can deliver 130W @ 55C outside ambient temperature
- Output overcurrent protection (non-latching)
- Overtemperature protection
- Output overvoltage protection
- Up to 11ms of holdup time
- Active power factor corrected input
- Conducted EMI - meets CISPR22 (EN55032) and FCC Class B requirements
- Meets IEC61000-4-5, Level 4 (2kV/4kV)
- Compliant to RoHS Directive 2011/65/EU and amended Directive (EU) 2015/863
- Compliant to REACH Directive (EC) No 1907/2006
- 1mil Conformal coated Z02A version passed Salt/Fog test and Mixed Flow Gas test
- Fuse in Neutral line in Z03A version for Japan market
- UL and cUL approved to UL/CSA62368-1, TUV (EN62368-1), CE Mark (for LVD) and CB Report available
- ISO™ 9001 and ISO 14001 certified manufacturing facilities

See footnotes on page 3

## Technical Specifications

### Absolute Maximum Ratings

Stresses in excess of the absolute maximum ratings can cause permanent damage to the device. These are absolute stress ratings only, functional operation of the device is not implied at these or any other conditions in excess of those given in the operations sections of the data sheet. Exposure to absolute maximum ratings for extended periods can adversely affect the device reliability.

Parameter	Device	Min	Max	Unit
Input Voltage - Continuous Operation	All	90	265	V <sub>ac</sub>
For up to 10 seconds max	All	90	275	V <sub>ac</sub>
Operating Ambient Temperature (see Thermal Considerations section) (in sealed enclosure applications with thermally conductive pad to enclosure, P <sub>O,max</sub> = 130W)	All	-40	85	°C
	All	-40	55	°C
Storage Temperature	All	-40	85	°C
Humidity (non-condensing)	All	5	95	%
Altitude	All		5000	m
Isolation Voltage - Input to output	All		3000	V <sub>ac</sub>
Input to safety ground	All		1500	V <sub>ac</sub>
Outputs to safety ground	All		50	V <sub>ac</sub>

† Ambient temperature outside the sealed enclosure containing the power supply.

### Electrical Specifications

Parameter	Device	Min	Typ	Max	Unit
Operating Input Voltage	All	90	115/230	265	V <sub>ac</sub>
Input Source Frequency	All	47	50/60	63	Hz
Input Current (V <sub>IN</sub> = 90V <sub>ac</sub> )	All			3	A <sub>RMS</sub>
Input Power Factor (115V <sub>ac</sub> or 230V <sub>ac</sub> in at Full Load)	All	0.95			
Inrush Transient Current (V <sub>IN</sub> = 265V <sub>ac</sub> , T <sub>amp</sub> = 25°C)	All			100	A Peak
Leakage Current to earth ground (V <sub>IN</sub> = 265V <sub>ac</sub> )	All			2	mA
Output Voltage Setpoint	All		12		V <sub>dc</sub>
Output Voltage Tolerance (due to set point, temperature variations, load and line regulation)	All	-3		3	%
Output Voltage Adjustment Range	All	11.7		12.6	V <sub>dc</sub>
Output Load Regulation	All			1	%V <sub>out</sub>
Output Line Regulation	All			0.5	%V <sub>out</sub>
Output Ripple and Noise – measured with 0.1µF ceramic capacitor in parallel with 10µF tantalum capacitor, at 25°C <sup>1</sup>	All			180	mV p-p
Peak-to-peak (20MHz Bandwidth)					
Dynamic Load Response – 50% to 75% load transient, 0.1A/µs slewrate. Output voltage deviation	All			5%	%
Settling Time	All			500	µs
Output Current	All	0		12.5	A <sub>dc</sub>
Output Current Limit Inception	All	110		145	% I <sub>O,max</sub>
Maximum Output Capacitance	All			5000	µF
Efficiency at 25°C:					
V <sub>IN</sub> = 230V <sub>ac</sub> , 20% load	All		89.3		%
50% load	All		92.9		%
100% load	All		92.7		%
V <sub>IN</sub> = 115V <sub>ac</sub> , 20% load	All		87.7		%
50% load	All		90.9		%
100% load	All		90.5		%
Holdup Time <sup>2</sup> - V <sub>IN</sub> = 115V <sub>ac</sub> or 230V <sub>ac</sub> , 100% load	All	11			ms

See footnotes on page 3

## Technical Specifications (continued)

### General Specifications

Parameter	Device	Symbol	Typ	Unit
Calculated Reliability based on Telcordia SR-332 Issue 2: Method 1 Case 3 ( $V_{IN}=230V_{ac}$ , $I_o = 12.5A$ , $T_A = 40^{\circ}C$ , airflow 200LFM, 90% confidence)	All	FIT MTBF	201.6 49600 60	$10^9$ / Hours Hours
Weight	All		184 6.5	g oz.

### Feature Specifications

Parameter	Device	Min	Typ	Max	Unit
Output Voltage Rise Time (from 10 to 90% of final value)	All		4.2		ms
Delay from Input being applied to all outputs being in regulation <sup>3</sup>	All			1000	ms
Output Overvoltage Protection (for main output currents above 0.1A)	All	13.8		17	$V_{dc}$
Input Undervoltage lockout <sup>4</sup>					
Turn-on Threshold (100% load)	All		83	90	$V_{ac}$
Turn-off Threshold (100% load)	All		72	88	$V_{ac}$

### Environmental Specifications

Parameter	Device	Specification
Conducted Emissions	All	CISPR32 (EN55032) Class B with 3dB margin
Radiated Emissions <sup>5</sup>	All	CISPR32 (EN55032) to comply with system enclosure
Input Harmonics	All	EN61000-3-2
ESD	All	IEC 61000-4-2, Level 3
Radiated Susceptibility <sup>6</sup>	All	IEC 61000-4-3, Level 2
Electrical Fast Transient Common Mode	All	IEC 61000-4-4, Level 3
Surge Immunity	All	IEC 61000-4-5, Level 4
Conducted RF Immunity	All	IEC 61000-4-6, Level 3
Voltage Dips	All	EN61000 4.11, Level 3, Class B, C
Shock and Vibration	All	IPC-9592B

#### Footnotes

\* UL is a registered trademark of Underwriters Laboratories, Inc.

† CSA is a registered trademark of Canadian Standards Association.

‡ VDE is a trademark of Verband Deutscher Elektrotechniker e.V.

“ ISO is a registered trademark of the International Organization of Standards

<sup>1</sup> Below  $-25^{\circ}C$ , ripple may exceed the specified level. Specification will be met after warm up period of 15s.

<sup>2</sup> Holdup time may be lower at cold temperatures

<sup>3</sup> Met when temperature is above  $-25^{\circ}C$  and restart duration is  $\leq 20s$ .

<sup>4</sup> Undervoltage lockout threshold may vary with output load current level – decreasing as load goes lower

<sup>5</sup> Shall be met when tested in a suitable enclosure

<sup>6</sup> Shall be met when tested in a suitable enclosure

# Technical Specifications (continued)

## Characteristic Curves

The following figures provide typical characteristics for the CLP0112 power supply.

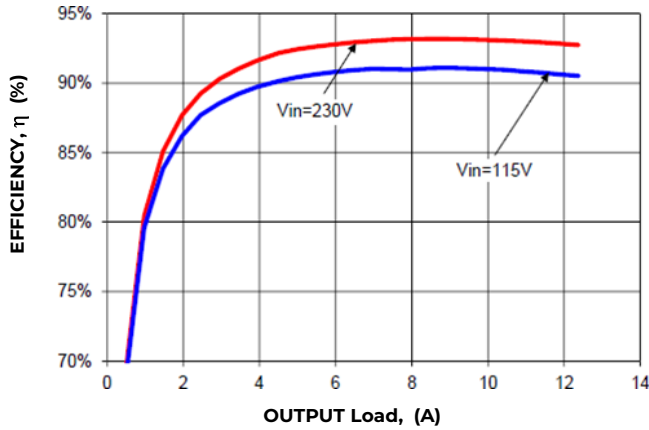

Figure 1. Converter Efficiency versus Output Current.

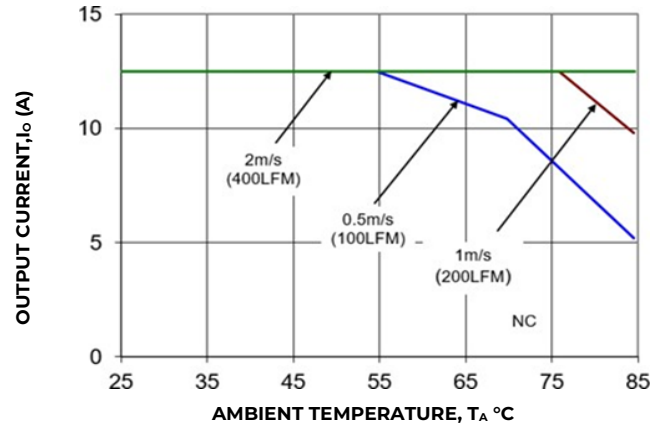

Figure 2. Derating Output Current versus Ambient Temperature and Airflow. Data shown for 115V<sub>AC</sub> in, at 230V<sub>AC</sub> in derating is the same or better. For derating at other input voltages, consult the OmniOn Technical representative.

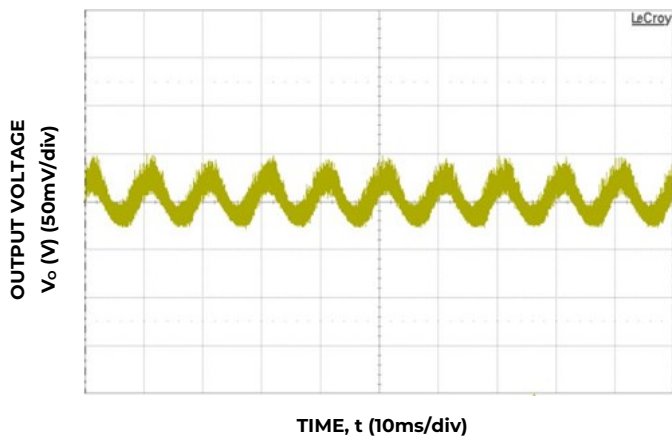

Figure 3. Typical output ripple and noise ( $V_{IN} = 230V_{ac}$ , 100% load).

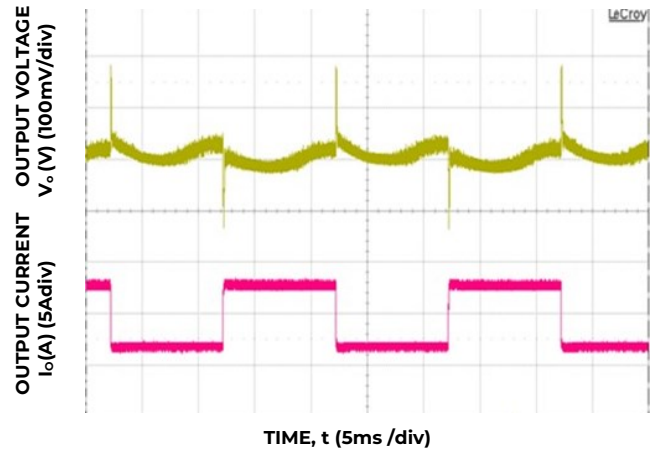

Figure 4. Transient Response to Dynamic Load Change from 50% to 100% at  $V_{IN} = 230V_{ac}$ .

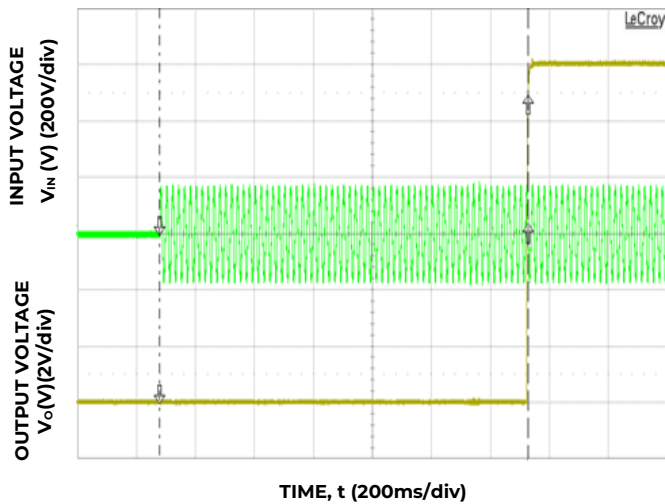

Figure 5. Typical Start-up ( $V_{IN} = 115V_{ac}$ ).

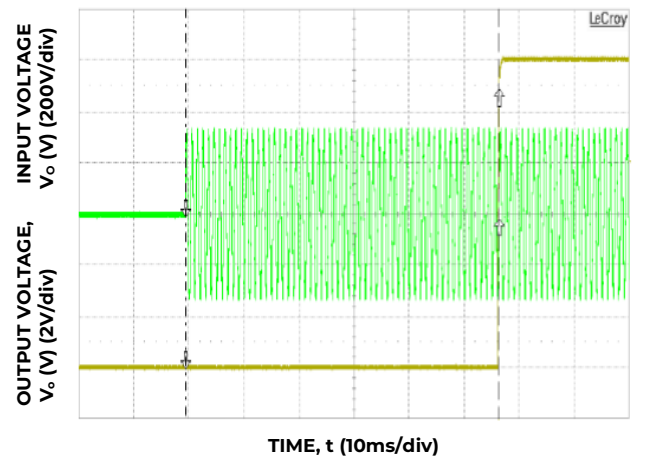

Figure 6. Typical Start-up ( $V_{IN} = 230V_{ac}$ ).

## Technical Specifications (continued)

### Characteristic Curves (continued)

The following figures provide typical characteristics for the CLP0112 power supply.

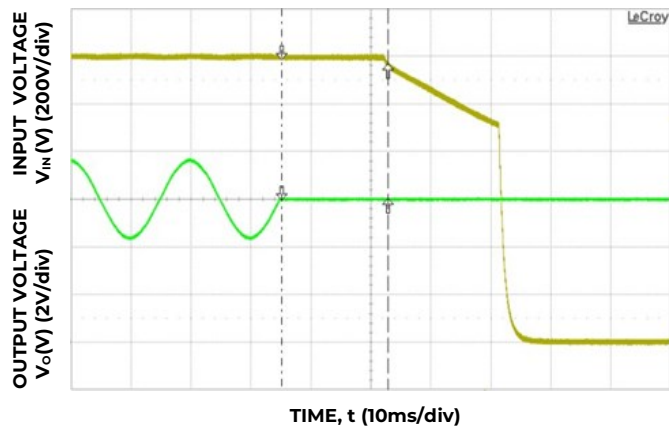

Figure 7. Typical Hold-up waveforms ( $V_{in} = 115V$ , 100% load).

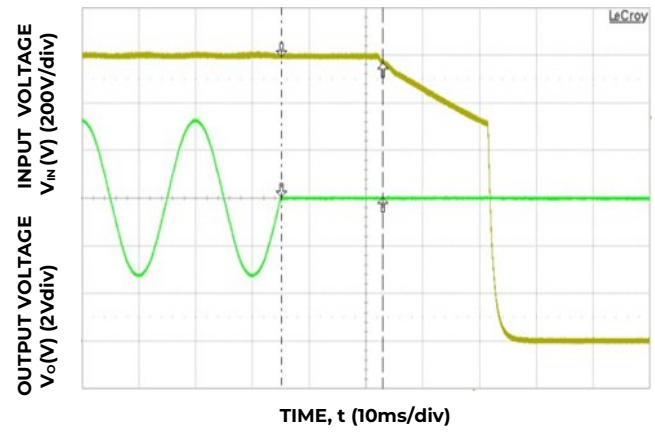

Figure 8. Typical Hold-up waveforms ( $V_{in} = 230V$ , 100% load).

## Technical Specifications (continued)

### Safety Considerations

The CLP0112 power supply is intended for inclusion in other equipment and the installer must ensure that it is complied with all the requirements of the end application. This product is only for inclusion by professional installers within other equipment and must not be operated as a stand-alone product. The power supply should meet Class 1, IEC62368, EN62368, with the following deviations: Nemko UL 62368 (Recognized Component) C-UL (Canadian Approval by UL).

### Feature Descriptions

#### Overcurrent Protection

To provide protection in a fault condition (output overload), the power supply is equipped with internal current-limiting circuitry and can endure current limiting continuously. At the point of current-limit inception, the unit enters hiccup mode. The power supply operates normally once the output current is brought back into its specified range.

#### Overvoltage Protection

Overvoltage protection is a feature of the CLP0112 power supply that protects both the load and the power supply from an output overvoltage condition. When an overvoltage occurs, the power supply shuts down and latches off. It is then necessary to recycle the input to restart the power supply when this protection is activated.

#### Overtemperature Protection

The CLP0112 also features overtemperature protection in order to provide additional protection in a fault condition. The power supply is equipped with a thermal shutdown circuit which detects excessive internal temperatures and shuts the unit down. Once the power supply goes into overtemperature shutdown, it will cool before attempting to restart. The overtemperature protection circuit will typically activate when the unit is operated at 150W output with an ambient temperature of 80°C and 1m/s (200LFM) airflow. Please note that at ambient temperatures of 75°C or higher and very low airflow conditions, the unit may need to have input voltage recycled before it turns back on from an OTP fault.

#### Input Undervoltage Lockout

At input voltages below the input undervoltage lockout limit, power supply operation is disabled.

The power supply will begin to operate at an input voltage above the undervoltage lockout turn-on threshold. Note that the undervoltage lockout limits are load dependent and the power supply turns ON and can operate at much lower input voltage levels when at light or no load.

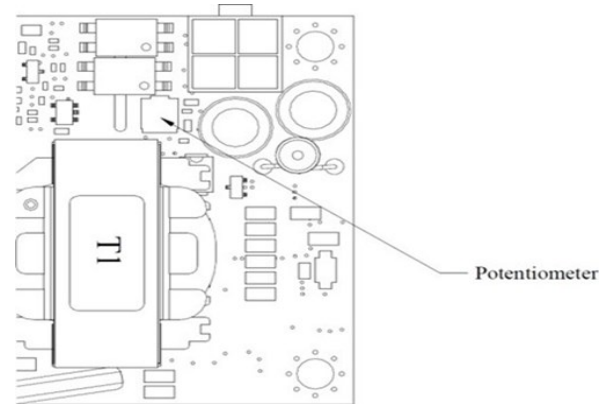

**Fig. 9. Diagram showing location of the potentiometer used to adjust the power supply output voltage.**

#### Output Voltage Adjustment

The output voltage can be adjusted between 11.7V and 12.6V using a potentiometer on the power supply. See Fig. 9 for a diagram showing location of the potentiometer.

#### Unique features in Z02A version

Z02A version has conformal coating (1mil thickness), and has passed environmental tests such as: salt fog test and mixed flow gas testing based on the following standards:

Mixed flow gas test Standard:

Telcordia GR-3108-CORE per R16-18[111], Outdoor Level, 14-Day (Mixed Flowing Gas)

Salt fog test standard:  
IEC 60068-2-52

#### Unique features in Z03A version

Z03A version has a fuse on Neutral wire in addition to the fuse on the Live Wire. Besides the extra fuse, the orientation of the output connector in Z03A is different from that in Z01A/Z02A. Please refer to mechanical outline.

## Technical Specifications (continued)

### Thermal Considerations

The power supply can be operated in a variety of thermal environments; however sufficient cooling should be provided to ensure reliable operation.

Considerations include ambient temperature, airflow, power supply dissipation and the need for increased reliability. A reduction in the operating temperature of the power supply will result in increased reliability. The thermal data presented here is based on measurements taken in a wind tunnel.

#### Heat Transfer via Convection

Increased airflow through the power supply enhances the heat transfer via convection. Figure 10 shows the preferred airflow direction. Contact your OmniOn technical representative for derating information in other airflow directions.

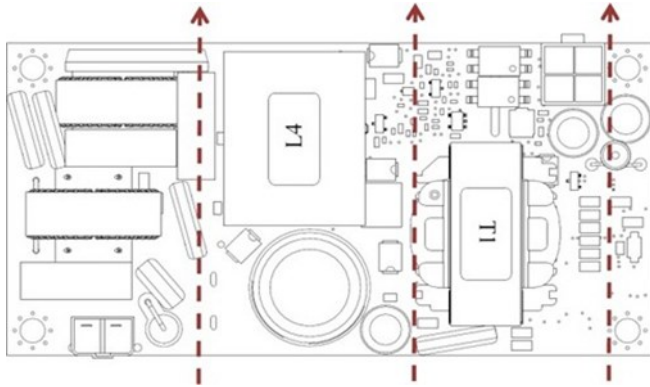

Fig. 10 Preferred airflow direction for cooling

#### Operation in a Sealed Enclosure

The CLP0112 power supply can also be operated in a sealed enclosure provided proper means for removing heat from the power supply are used. Figure 11 shows an arrangement where a thermally conductive pad is used to transfer heat from the bottom of the power supply into the enclosure. Under such conditions, the power supply is capable of reduced power operation as shown in Table 1. Note that the Ambient Temperature shown in Table 1 is that outside the sealed enclosure, the CLP0112 may see higher ambient temperatures.

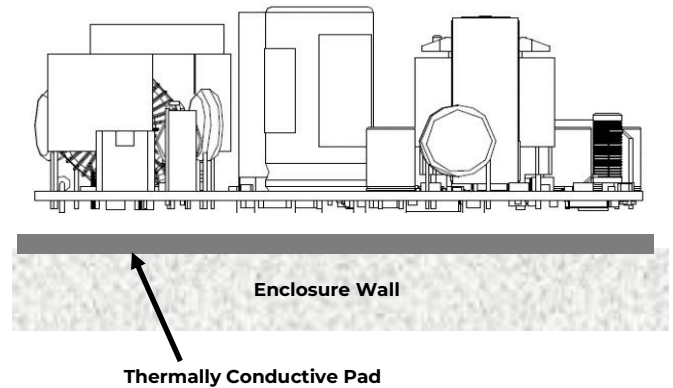

Fig. 11 Example arrangement of the CLP0112 for sealed enclosure application

Thermal conductivity should be 3.0 W/m-K for thermal pad application and 1kV+ isolation, example:

Thermal gap pad:

[http://www.bergquistcompany.com/pdfs/dataSheets/P\\_DS\\_GP\\_HC3\\_0714%20v7.pdf](http://www.bergquistcompany.com/pdfs/dataSheets/P_DS_GP_HC3_0714%20v7.pdf)

Thermal gap pad:

<https://www.lairdtech.com/products/tputty-502>

#### Assembling

- Please use metal screw to mount the unit and make sure 4 mounting holes connected to Earth well.
- In Applications where the power supply is enclosed, special attention to clearances between the supply and the enclosure should be a min. 3.5mm on all sides for improved safety. For additional protection, a layer of Kapton tape (3 mil thickness), covering the whole surface under the supply is recommended. If a cover is used a 3 mil Kapton Tape covering the whole cover is also recommended. Please contact your local OmniOn FAE if further information is need.

Ambient Temperature (°C)	Max. Output Power (W)
25	150
40	150
55	130

Table 1. Output Power Capability when the CLP0112 is operated in a sealed enclosure with thermal pad for conduction cooling.

# Technical Specifications (continued)

## Mechanical Outline

Dimensions are in millimeters.

Tolerances: x.x mm ± 0.5mm [unless otherwise indicated]

x.xx mm ± 0.25mm

**TOP VIEW  
( Z01A & Z02A )**

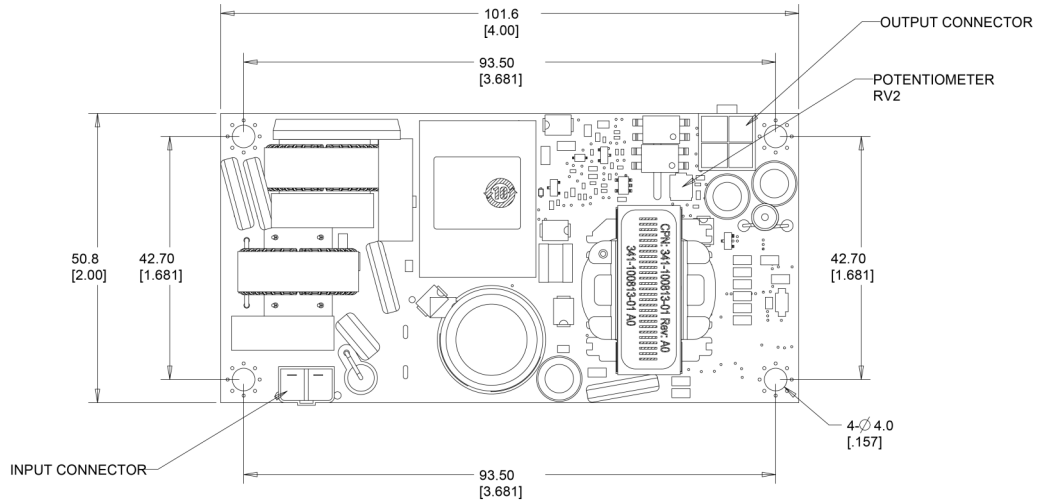

**SIDE VIEW**

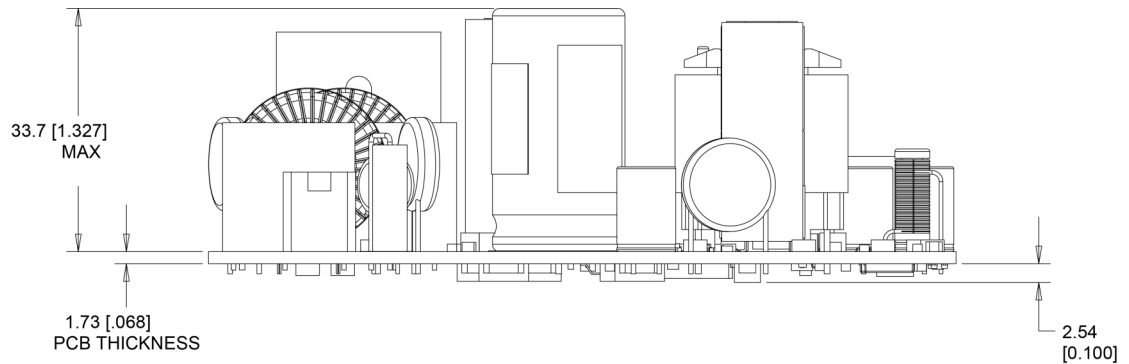

**3D - VIEW  
( Z01A & Z02A )**

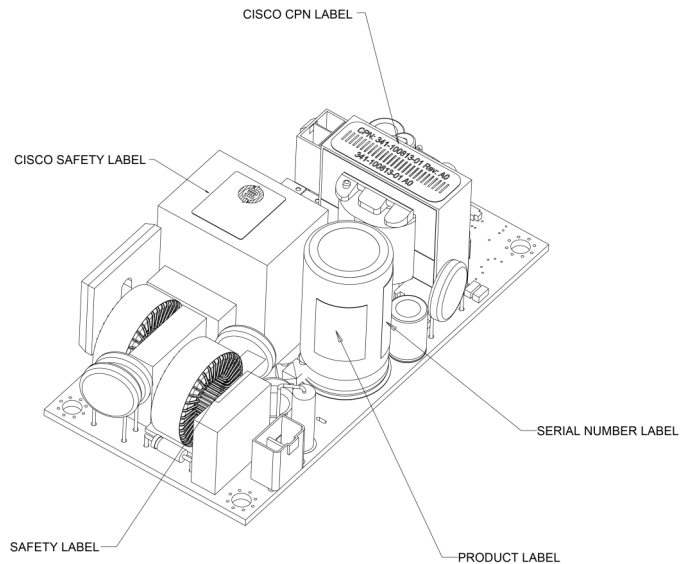



# Technical Specifications (continued)

## Mechanical Outline (continued)

Dimensions are in millimeters.

Tolerances: x.x mm ± 0.5mm [unless otherwise indicated]

x.xx mm ± 0.25mm

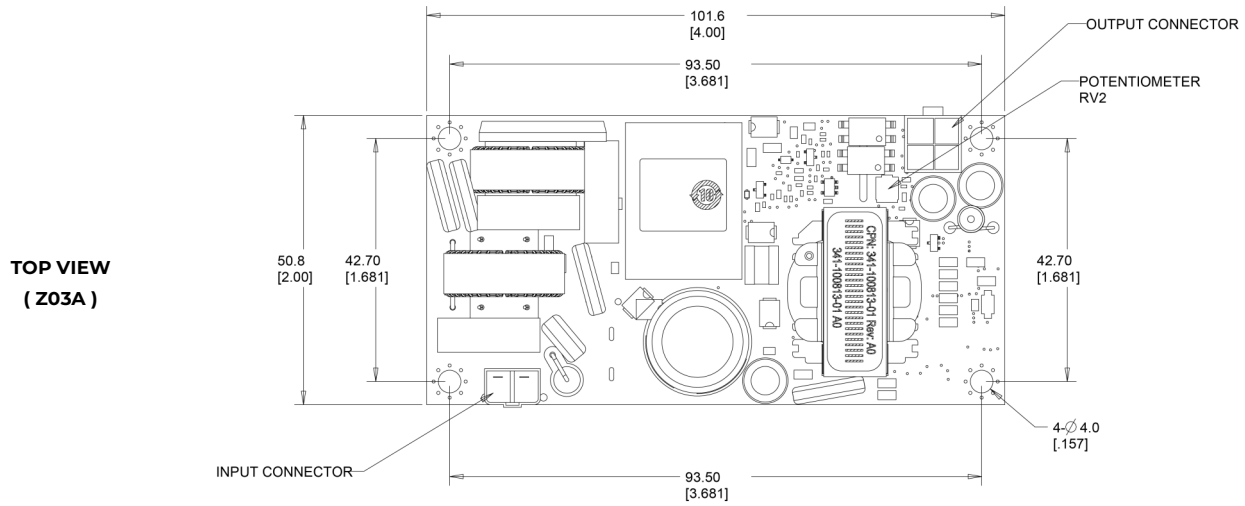

## Change History (excludes grammar & clarifications)

Revision	Date	Description of the change
10.3	10/11/2021	Updated as per template
10.4	05/31/2023	Correction in electrical specification table on
10.5	11/02/2023	Updated as per OmniOn template
10.6	01/04/2024	Updated images in mechanical outline

## Technical Specifications (continued)

### Connector Information

Connector	Connector on Power Supply	Mating Connector
AC Input Connector (HDR1)	5-1376382 from TE or equivalent	1376388-1 from Tyco or equivalent
DC Output Connector (HDR2)	39-28-8040 from Molex or equivalent	39-01-3048 from Molex or equivalent

### Pinout Information

AC Input Connector (HDR1)		DC Output Connector (HDR2)	
Pin 1	Line	Pin 1	VO
Pin 2	Neutral	Pin 2	VO
		Pin 3	RTN
		Pin 4	RTN

### Ordering Information

Please contact your OmniOn Sales Representative for pricing, availability and optional features.

Device Code	Input Voltage Range	Output Voltage	Output Current	Temperature Range	Ordering Codes
CLP0112FPXXXZ01A	90 – 265V <sub>ac</sub>	12.0V <sub>dc</sub>	12.5A	-40 to 85°C	150039432
CLP0112FPXXXZ02A (conformal coated)	90 – 265V <sub>ac</sub>	12.0V <sub>dc</sub>	12.5A	-40 to 85°C	CLP0112FPXXXZ02A
CLP0112FPXXXZ03A (Dual Fuse Version. Added fuse in Neutral)	90 – 265V <sub>ac</sub>	12.0V <sub>dc</sub>	12.5A	-40 to 85°C	CLP0112FPXXXZ03A

Table 2. Device Codes

### Contact Us

For more information, call us at

+1-877-546-3243 (US)

+1-972-244-9288 (Int'l)

**OmniOn Power Inc.**

601 Shiloh Rd.  
Plano, TX USA

[omnionpower.com](http://omnionpower.com)

We reserve the right to make technical changes or modify the contents of this document without prior notice. OmniOn Power does not accept any responsibility for errors or lack of information in this document and makes no warranty with respect to and assumes no liability as a result of any use of information in this document.

We reserve all rights in this document and in the subject matter and illustrations contained therein. Any reproduction, disclosure to third parties or utilization of its contents – in whole or in parts – is forbidden without prior written consent of OmniOn Power. This document does not convey license to any patent or any intellectual property right. Copyright© 2023 OmniOn Power Inc. All rights reserved.