

DATASHEET

CC2725AC34TZL Conduction-Cooled, Wide-Output Range Rectifier

200-240V_{AC} Input; 2,725W-Capable; 34V_{DC} Default Output; RoHS Compliant



Description

The CC2725AC34TZL rectifier has an extremely wide programmable output voltage capability. Featuring high-density, fully enclosed, conduction-cooled packaging, it is designed for minimal space utilization and is highly expandable for future growth. This standard rectifier incorporates both RS485 and I²C communications buses that allow it to be used in a broad range of applications. Feature-set flexibility makes this rectifier an excellent choice for applications requiring operation over a wide output-voltage range and conduction cooling.

Applications

Applications include: Wide Band Power Amplifier; Broadcast Systems; Lasers; Acoustic Noise Sensitive Systems; LED Signage.

Features

- Compliant to RoHS Directive 2011/65/EU and amended Directive (EU) 2015/863 (-Z versions)
- Compliant to REACH Directive (EC) No 1907/2006
- Peak efficiency 94%
- Completely enclosed, conduction cooled
- Output constant power 2,725W from 36-32V_{DC}
- Output voltage programmable from 28V-36V_{DC}
- Remote ON/OFF control of the main output
- Comprehensive input, output and overtemp protection
- Power factor correction (meets EN/IEC 61000-3-2 and EN 60555-2 requirements)
- Redundant, parallel operation with active load Sharing
- Redundant 5V Aux power
- Four front panel LED indicators
- Analog status signals
- Trim port to adjust V_o
- PMBus®-compliant I²C serial bus and RS485
- RoHS 6 compliant
- CB report
- CE mark meets 2014/30/EU directive
- NRTL Recognized

See Footnote on Page No. 7

Technical Specifications

Absolute Maximum Ratings

Stresses over the absolute maximum ratings can cause permanent damage to the device. These are absolute stress ratings only. Functional operation of the device is not implied at these or any other conditions over those given in the operations sections of the data sheet. Exposure to absolute maximum ratings for extended periods can adversely affect the device reliability.

Parameter	Symbol	Min	Max	Unit
Input Voltage - Continuous Operation	V_{IN}	0	264	V_{AC}
Operating Case Temperature (sink side)	T_C	-40 ¹	40 ²	°C
Storage Temperature	T_{stg}	-40	85	°C

Electrical Specifications

Unless otherwise indicated, specifications apply overall operating input voltage, $V_o=34V_{DC}$, resistive load, and temperature conditions.

INPUT					
Parameter	Symbol	Min	Typ	Max	Unit
Startup Voltage High-line Operation	V_{IN}			185	V_{AC}
Operating Voltage Range High-line configuration	V_{IN}	185	200-240	264	V_{AC}
Voltage Swell (no damage)	V_{IN}	305			V_{AC}
Low Voltage Turn Off	V_{IN}	175			V_{AC}
Turn On	V_{IN}			185	V_{AC}
Hysteresis	V_{IN}		10		V_{AC}
High Voltage Turn Off	V_{IN}			275	V_{AC}
Turn On	V_{IN}	265			V_{AC}
Hysteresis	V_{IN}		10		V_{AC}
Frequency	F_{IN}	47		63	Hz
Operating Input Current (185 V_{ac} , 100% load)	I_{IN}			16.5	A_{AC}
Inrush Transient (220 V_{RMS} , $T_C=25^\circ C$, excluding X-Capacitor charging)	I_{IN}		25	30	A_{PK}
Leakage Current (265 V_{AC} 60Hz)	I_{IN}			3.5	mA
Power Factor (50 - 100% load)	PF	0.96	0.98		
Efficiency, 240 V_{AC} , 34 V_{DC} , $T_C=25^\circ C$ 20% - 90% of FL	n	93	94%		%
Holdup time (output allowed to decay down to 26 V_{DC}) w/full load	T		12		ms
Ride through (at 240 V_{AC} , 25°C, $V_o>28V_{DC}$ with full load)	T	1/2			cycle
Isolation (per EN62368-1) <small>consult factory for testing to this requirement</small> Input to Chassis & Signals	V	1500			V_{AC}
Input to Output	V	3000			V_{AC}

See Footnote on Page No. 7

Technical Specifications (continued)

Electrical Specifications (continued)

MAIN OUTPUT					
Parameter	Symbol	Min	Typ	Max	Unit
Output Power @ high line input 200 – 240V _{AC} , V _O ≥ 32V _{DC} , T _C ≤ 40°C	W	2725			W _{DC}
Factory set default set point	V _{OUT}		34		V _{DC}
Overall regulation (load, temperature, aging) 0-T _C ≤ 40°C, Load > 2.5A	V _{OUT}	-1		-1	%
Output Voltage Set Range	V _{OUT}	28		36	V _{DC}
Output Current ³ - T _C ≤ 40°C					
36V	I _{OUT}	1		75.7	A _{DC}
34V	I _{OUT}	1		80	A _{DC}
32V	I _{OUT}	1		85	A _{DC}
30V	I _{OUT}	1		85	A _{DC}
28V	I _{OUT}	1		85	A _{DC}
Current Share (> 50% FL)					
V _O > 30V _{DC}		-5		5	%FL
V _O < 30V _{DC}		-10		10	%FL
Output Ripple (20MHz bandwidth, load > 1A)					
RMS (5Hz to 20MHz)	V _{OUT}			100	mV _{rms}
Peak-to-peak (5Hz to 20MHz)				500	mV _{p-p}
External Bulk Load Capacitance	C _{OUT}	0		5,000	mF
Turn on (monotonic turn-ON from 30 - 100% of V _{nom} above 5°C)					
Delay			5		s
Rise Time - PMBus mode	T		100		ms
Rise Time - RS-485 mode			100		ms
Output Overshoot	V _{OUT}			2	%
Load Step Response ⁴ (I start from 0A), V _O =34V					
ΔI	I _{OUT}			90	%FL
ΔV	V _{OUT}		2.0		V _{DC}
Response Time ⁵	T		2		ms
Overvoltage					
200ms delayed shutdown	V _{OUT}	>40		<40	V _{DC}
Immediate shutdown					
Latched shutdown					
Three restart attempts are implemented with a 1-minute window prior to a latched shutdown.					
Overtemperature warning (prior to commencement of shutdown)			5		
Shutdown (below the max device rating being protected)	T		20		°C
Restart attempts Hysteresis (below shutdown level)			10		
Isolation Output to Chassis	V	100			V _{DC}

See Footnote on Page No. 7

Technical Specifications (continued)

Electrical Specifications (continued)

MAIN OUTPUT (continued)

Parameter	Symbol	Min	Typ	Max	Unit
Power limit down to 32V _{DC}	P _{OUT}	2725			W
<ol style="list-style-type: none"> Dynamic Current limit threshold varies corresponding Vo set point and V_{in} The overload current limit threshold is set at least > 1% above the load envelope shown here Overcurrent events that exceed the envelope by 2% will hiccup continuously at a frequency of approximately once every 24 seconds Dynamic output UV protection Vo, set -2V is introduced when Vo set is <TBD Fixed output UV protection 36V when Vo set >TBD 					

CC2725AC34TZL Output Current Curve

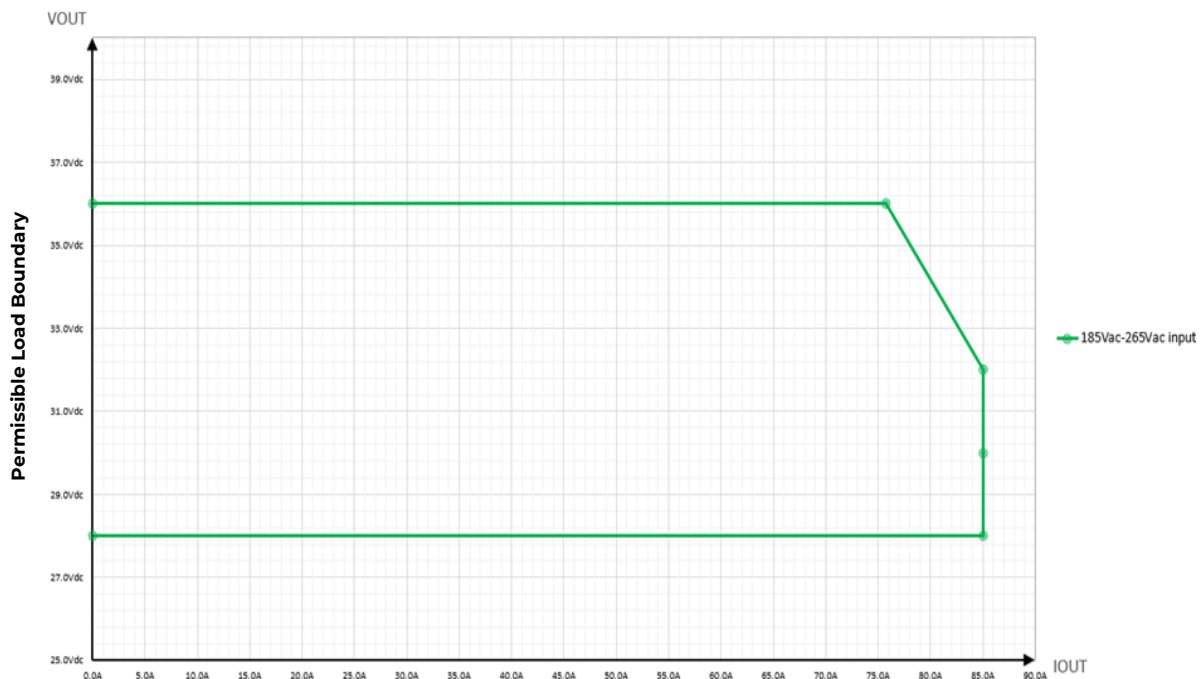

185-240Vac input

V _o (V _{dc})	28	30	32	34	36
I _o (A)	85.0	85.0	85.0	80.1	75.7

Define Po curve at case temp 40°C. Ambient temp is less than 30°C.

Contract terms are for supporting all loads inside the load map. The customer will develop a control interface which maintains the operating voltage and current so as to not exceed the load map.

System power up: Upon insertion, the rectifier will delay an overload shutdown for 20 seconds.

See Footnote on Page No. 7

Technical Specifications (continued)

Electrical Specifications (continued)

5V_{DC} Auxiliary Output (return is LGND)					
Parameter	Symbol	Min	Typ	Max	Unit
Output Voltage Setpoint	V _{OUT}		5		V _{DC}
Overall Regulation		-10		+5	%
Output Current		0		0.2	A
Ripple and Noise (20mHz bandwidth)			55	200	mV _{p-p}
Over-voltage Clamp				7	V _{DC}
Overcurrent Limit		400		670	%FL
Isolation LGND to Chassis		100			V _{DC}

The 5V_{DC} should be ON before availability of the main output and should turn OFF only if insufficient input voltage exists to provide reliable 5V_{DC} power. The PG signal should have indicated a warning that main output has turned OFF and the 34V_{DC} main output should be OFF way before interruption of the 5V_{DC} output.

General Specifications

Parameter	Min	Typ	Max	Units	Notes
Reliability		TBD		Hours	Full load, 25°C, MTBF per SR232 Reliability protection for electronic equipment, issue 2, method I, case III
Service Life		10		Years	At 80% load and 25°C cold plate
Unpacked Weight		TBD		Kg	
Packed Weight		TBD		Kg	

See Footnote on Page No. 7

Technical Specifications (continued)

Signal Specifications

Unless otherwise indicated, specifications apply to overall operating input voltage, resistive load, and temperature conditions. Signals are referenced to LGND unless noted otherwise.

Parameter	Symbol	Min	Typ	Max	Unit
Enable (Analog or PMBus Mode)					
Main Output OFF	V_{OUT}	2.4		5	
Main Output ON (should be connected to LGND)	V_{OUT}	0		0.4	
Enable RS485 (RS485 model -- Referenced to V_{out-})					
Main Output OFF	V_{OUT}	2.4		5	
Main Output ON (should be connected to V_{out-})	V_{OUT}	0		0.4	
Margining (by adjusting "Margining"; see "Voltage					
Programmed output voltage range	V_{OUT}	28		36	
Linear voltage control range	$V_{control}$	≥ 0.1	36	≥ 3.0	
Voltage adjustment resolution (8-bit A/D)	$V_{control}$				
Output set to $34V_{DC}$	$V_{control}$	3.1		3.3	
Output set to $28V_{DC}$	$V_{control}$	0		0.1	
Over Temperature Warning (OTW)					
Logic Hi (temperature normal)	V	2.4		3.3	
Sink current (note: open collector output FET)	I			5	
Logic LO (temperature is too high)	V	0		0.4	
Fault					
Logic Hi (temperature normal)	V	2.4		3.3	
Sink current (note: open collector output FET)	I			5	
Logic LO (internal fault occurred)	V	0		0.4	
Power Good Warning (PG)					
Logic Hi (normal)	V	2.4		3.3	
Sink current (note: open collector output FET)	I			5	
Logic LO (Main Output OFF)	V	0		0.4	

Environmental Specifications

Parameter	Min	Typ	Max	Units	Notes
Operating Case Temperature	-40 ⁶		40	°C	Measured at the center of the cooling surface. Refer to detailed power boundary curves.
Storage Temperature	-40		85	°C	
Operating Altitude			5000/ 16,463	m/ ft	
Non-operating Altitude			8200/ 27,000	m/ ft	
Over Temperature		115		°C	Shutdown/restart (internally)
Humidity					
Operating	5		95	%	Relative humidity, non-condensing
Storage	5		95	%	
Shock and Vibration			2.4	Grms	

See Footnote on Page No. 7

Page 6

Technical Specifications (continued)

EMC

Parameter	Measurement	Standard	Level	Test
	Conducted emissions ⁷	EN55032	A +3dB margin	0.15 - 30MHz
AC Input	Radiated emissions ⁸	EN55032	A +3dB margin	30 - 1000MHz
	Line harmonics	EN610000-3-2 THD	Table 1 5%	0 - 2kHz 230 Vac, full load,
Parameter	Measurement	Standard	Criteria ⁶	Test
AC Input Immunity	Line sags and interruptions	EN610000-4-11	8	-30%, 10ms
			8	-60%, 100ms
			8	-100%, 5sec
		Output will stay above 26V°C @75% load ; sag must be higher than 80Vrms	A	25% line sag for 2 seconds 0.5 cycle interruption
	Lightning surge	EN610000-4-5, Level 4, 1.2/50ms - error free	A	4kV, common mode
			A	2kV, differential mode
Fast transients	EN610000-4-4, Level 3	B	5/50ns, 2kV (common mode)	
Enclosure Immunity	ESD	EN610000-4-2, Level 4	B	8kV contact, 15kV air

Footnotes :

⁷ ISO is a registered trademark of the International Organization of Standards

¹ Designed to start and work at an ambient as low as -40°C, but meet operational limits until above -5°C

² Refer to power curve (Vo vs Io)

³ Refer to power curve on page 4

⁴ Allow to add ext Co bank

⁵ Vo undershoot around 2V may take longer time to recover

⁶ Designed to start and work at an ambient as low as -40°C, but meets operational limits until about -5°C

⁷ Test with external filter

⁸ Test with external filter

⁹ Criteria A: The product must maintain performance within specification limits. Criteria B: Temporary degradation which is self-recoverable. Criteria C: Temporary degradation which requires operator intervention.

Technical Specifications (continued)

Control and Status

The Rectifier provides three means for monitor control: analog, PMBus®, or the OmniOn Galaxy-based RS485 protocol. Details of analog control are provided in this data sheet. OmniOn will provide separate application notes on the Galaxy RS485 or PMBus® based protocol for users to interface to the rectifier. Contact your local OmniOn representative for details. Factory default setting is Analog & PMBus® mode.

Analog Controls

Details of analog controls are provided in this data sheet under Feature Specifications. Note that some signals are ignored in RS485 mode.

Signal Reference

Unless otherwise noted, all signals are referenced to LGND (“Logic Ground”). See the Signal Definitions Table at the end of this document for further description of all the signals.

LGND is isolated from the main output of the rectifier for PMBus communications. Communications and the 5V standby output are not connected to main power return ($V_{out}(-)$) and can be tied to the system digital ground point selected by the user. (Note that RS485 communications is referenced to $V_{out}(-)$, main power return of the rectifier).

LGND is capacitively coupled to Earth Ground inside the rectifier where Earth Ground is also wired to the metal case). The maximum voltage differential between LGND and Earth Ground should be less than $100V_{DC}$.

Delayed Overcurrent Shutdown During Startup

Rectifiers are programmed to stay in a constant current state for up to 20 seconds during power up. This delay has been introduced to permit the orderly application of input power to a subset of paralleled front-ends during power up. If the overload persists beyond the 20 second delay, rectifier will shut down and restart.

Auto Restart

Auto-restart is the default configuration for over-current and over-temperature shutdowns

An overvoltage shutdown is followed by three attempted restarts, each restart delayed 1 second, within a 1 minute window. If within the 1 minute window three attempted restarts failed, the unit will

latch OFF. If within the 1 minute less than 3 shutdowns occurred then the count for latch OFF resets and the 1 minute window starts all over again.

To restart after a latch off either of five restart mechanisms are available.

1. The hardware pin ON/OFF or DIP switch on rear side may be cycled OFF and then ON.
2. Turn OFF and then turn ON AC power to the unit.
3. The unit may be commanded to restart via i2c through the Operation command by cycling the output OFF followed by ON.

Control Signals

There are two DIP switches and a port on rear side of rectifier, to provide way to adjust output voltage setpoint and remote on/off main power output.

A separated signal connector includes all the control and status signals.

Protocol

Establishes the communications mode of the rectifier, between analog/I²C and RS485 modes. For RS485, connect 10kΩ pull-down resistor to $V_{out}(-)$. Default setting of signal interface is open.

Margining

There is a trim port on rear panel of rectifier to provide an easy to adjust output voltage set-point. A DIP switch in off disable this trim pot when need to use external analog signal to adjust V_o through margin pin.

Output voltage set-point will return to factory default set-point once DIP switch for trim pot is off.

Factory default setting is switch on.

The margining pin from signal interface can also be used to adjust the output voltage set-point once DIP is off.

The margining pin is connected to $3.3V_{dc}$ via a 8.87kΩ resistor inside the Rectifier. Connecting a resistor or voltage source externally can change set-point.

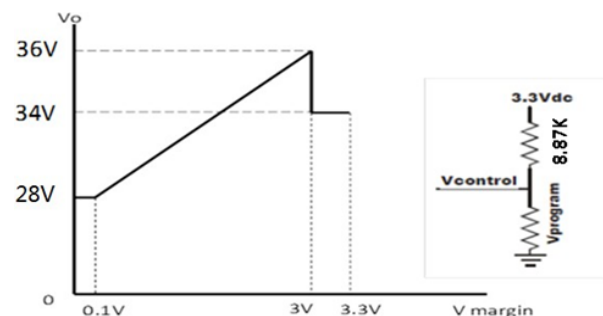

Technical Specifications (continued)

Margining (continued)

Note that in RS485 mode the margining function include trim port and DIP switch is ignored.

Please contact your local representative for details about how to change output voltage set-point through RS485 communication.

ON/OFF

There is an on/off DIP switch on rear panel of rectifier to provide on/off main power output manually.

Factory default setting is switch on.

Enable pin from signal interface can be used to control main power on/off in case on/off DIP switch is off. This pin must be pulled low to turn ON the rectifier.

Note that in RS485 mode the ON/OFF pin is ignored.

Enable_RS485

This pin is used as main power on/off in RS485 mode. In I²C/ analog mode, this pin is ignored.

Status Signals

Power Good Warning (PG)

A TTL-compatible status signal representing whether main output is delivered. This signal needs to be pulled HI externally through a resistor.

This signal is HI when the main output is being delivered and goes LO when main power is shutdown. This signal deliver duty in case output current limit condition.

Fault

A TTL-compatible status signal representing whether a internal Fault occurred. This signal needs to be pulled HI externally through a resistor.

This signal goes LO for any failure that requires rectifier replacement. These faults may be due to:

- Over-temperature shutdown
- Over-voltage shutdown
- Internal Rectifier Fault

In RS485 mode, this pin is ignored.

Over Temp Warning (OTW#)

A TTL-compatible status signal representing whether an over temperature exists. This signal needs to be pulled HI externally through a resistor.

If an over temperature should occur, this signal would pull LO for approximately 10 seconds prior to shutting down the rectifier. In its default configuration, the unit would restart if internal temperatures recover within normal operational levels. At that time the signal reverts back to its open collector (HI) state.

In RS485 mode, this pin ignored .

Technical Specifications (continued)

Front Panel LEDs

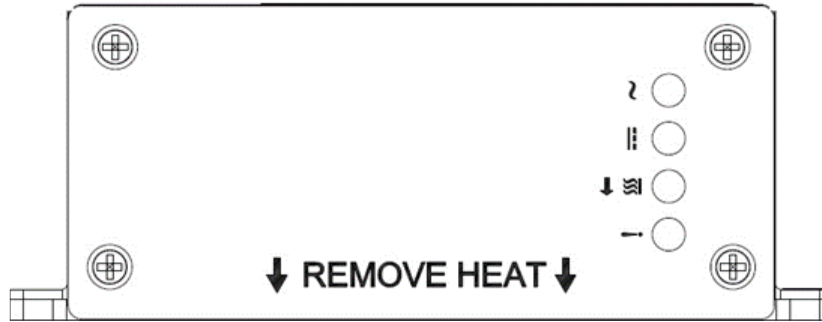

	Analog Mode	I ² C Mode	RS485 Mode
<input type="checkbox"/> ~	←	ON: Input ok Blinking: Input out of limits	→
<input type="checkbox"/> ≡	←	ON: Output ok Blinking: Overload	→
<input type="checkbox"/> ⏏ *	ON: Over-temperature Warning	ON: Over-temperature Warning Blinking: Service	ON: Over-temperature Warning
<input type="checkbox"/> !	←	ON: Fault	ON: Fault Blinking: Not communicating

*Arrow next to "hot" symbol points to the cooling side, where heat should be removed.

Condition	Rectifier LED State				Monitoring Signals		
	AC OK Green	DC OK Green	Service Amber	Fault Red	Fault	OTW	PG
OK	1	1	0	0	HI	HI	HI
Thermal Alarm (5°C before)	1	1	1	0	HI	LO	HI
Thermal Shutdown	1	0	1	1	LO	LO	LO
AC Present But Not Within Limits	Blinks	0	0	0	HI	HI	LO
AC Not Present ¹	0	0	0	0	HI	HI	LO
Boost Stage Failure	1	0	0	1	LO	HI	LO
Overvoltage Latched Shutdown	1	0	0	1	LO	HI	LO
Over Current	1	Blinks	0	0	HI	HI	Pulsing ⁴
Non-catastrophic Internal Failure ²	1	1	0	1	LO	HI	HI
Standby Remote ⁵	1	0	0	0	HI	HI	LO
Service Request (PMBus Mode)	1	1	Blinks	0	HI	HI	HI
Communications Fault (RS485)	1	1	0	Blinks	N/A	N/A	High

¹ This signal is correct if another powered units provides 5VA and 8VINT as back-bias.

² Any detectable fault condition that does not cause a shutting down. For example, ORing FET failure, boost section out of regulation, etc.

⁴ Pulsing at a duty cycle of 1ms as long as the unit is in overload.

⁵ Remote on/off, or I²C command in i2c mode. or through interlock or GP command in RS485 mode.

Table 1: Alarm and LED State Summary

Technical Specifications (continued)

Mechanical Outline

All dimensions are in mm

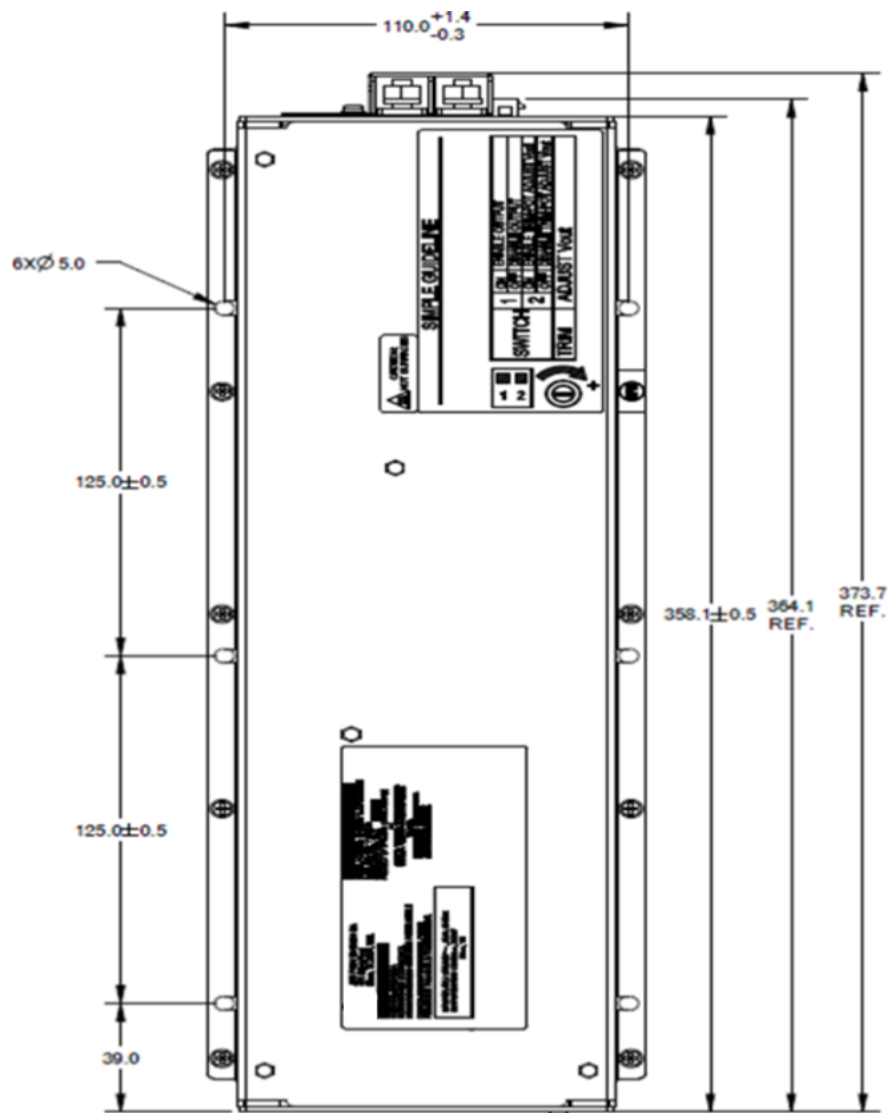

TOP VIEW

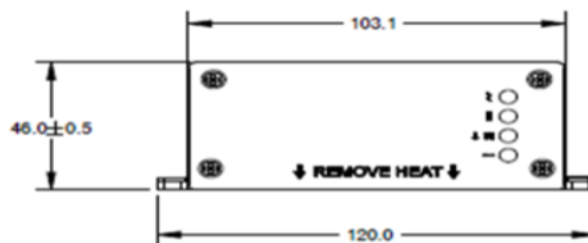

FRONT VIEW

Technical Specifications (continued)

Wiring Interface

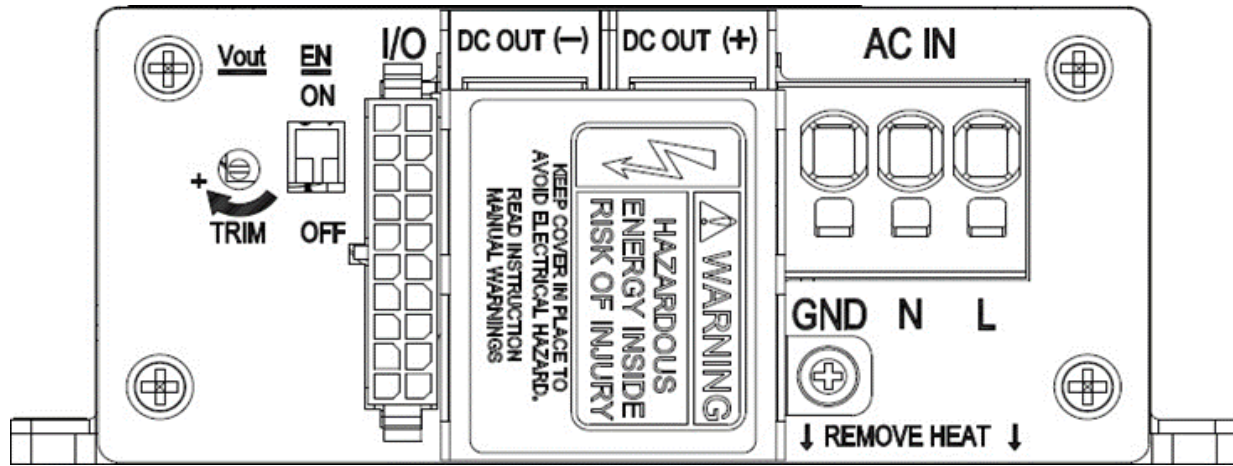

Rear View

AC Input Wiring Diagram



Whether it's a push-in spring or a leg spring, the spring principle makes for quick, tool-free conductor connection. Simply insert the solid conductors and conductors with ferrules into the push-in terminal point and release using a screwdriver. When connecting and releasing finely stranded conductors without ferrules, the terminal point can also be opened using a screwdriver.

TB/Connector	Vendor P/N	Rated Current	Rated Insulation Voltage	Pitch	Pos.
AC Input	1719202 (Phoenix)	41A	1000V	7.5mm	3

TB Connection Data	AC Input TB
Conductor cross section solid	0.2 - 10mm ²
Conductor cross section flexible	0.2 - 6mm ²
Conductor cross section with ferrule without plastic sleeve	0.25 - 6mm ²
Conductor cross section with ferrule with plastic sleeve	0.25 - 4mm ²
Conductor cross section AWG	24-8 AWG
Nominal current I _N	41A
Stripping length	15mm

Wire Information for AC Input TB

Note: Recommended to use ferrule with correct stripping length for input.

Technical Specifications (continued)

DC Output Wiring Diagram

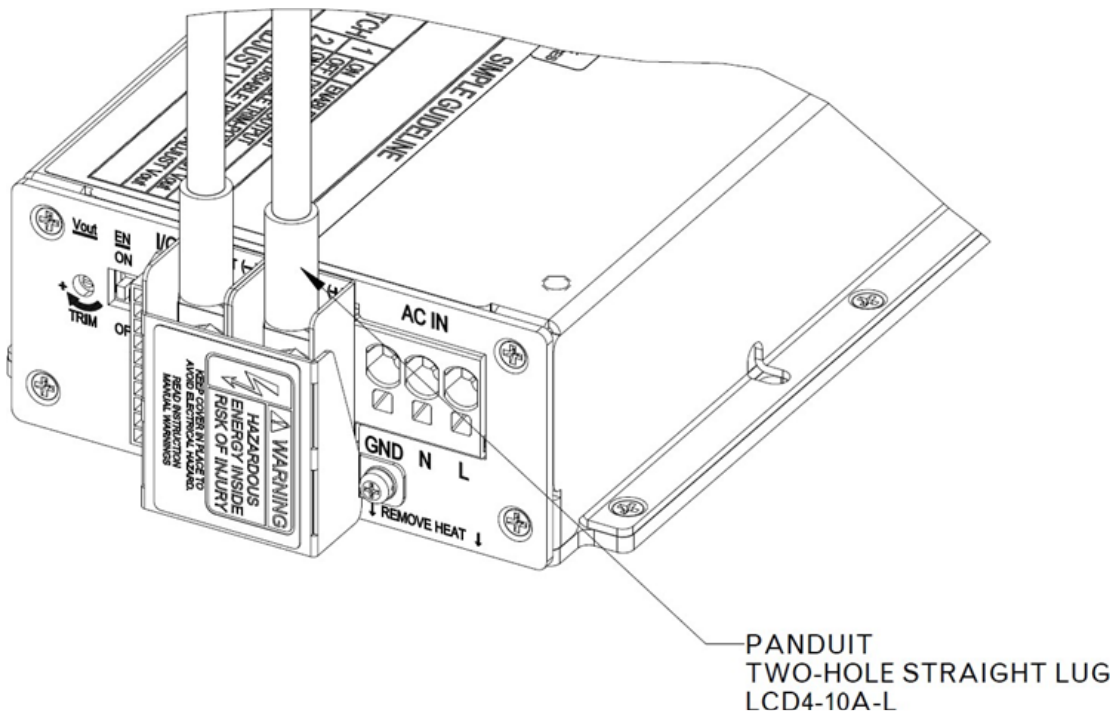
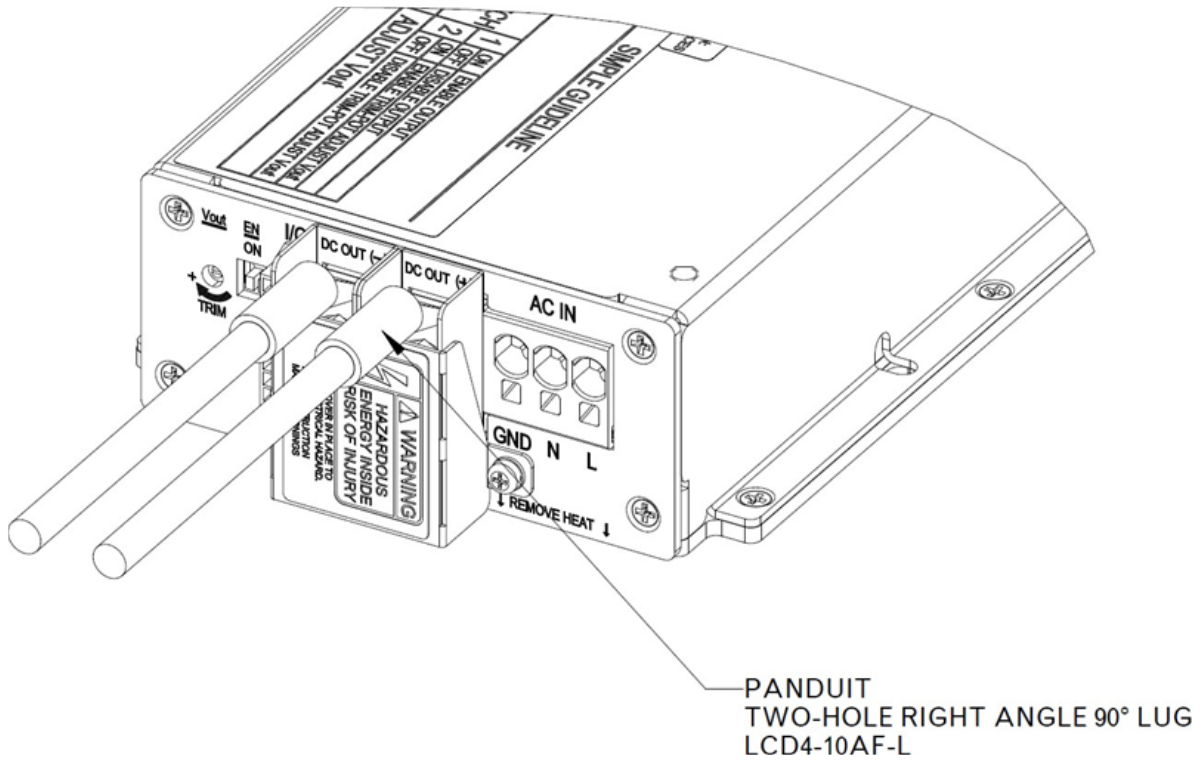

Technical Specifications (continued)

Signal I/O Pin Definition

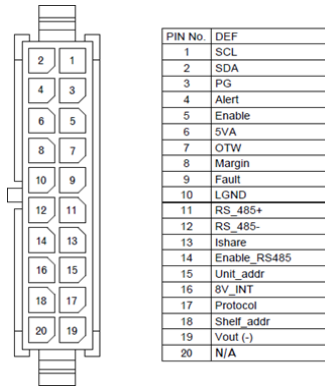

Pins Table

TB/Connector	Vendor P/N	Rated Current	Rated Insulation Voltage	Pitch	Pos.
Signal I/O	430202000 (Molex)	5A (UL)	350V (UL)	3.0mm	20

Signal Definitions

I/O	Function	Type	Description
SCL	I ² C Line	Input	I ² C 0 channel
SDA	I ² C Line	Input	I ² C 0 channel
PG	Power Good Warning	Output	Open drain FET; normal is High, Changes to Low if an imminent loss of the main output may occur. Ref: LGND
Alert	I ² C Interrupt	Output	I ² C 0 channel
Enable	Output Control	Input	If shorted to LGND, main output is ON in Analog or PMBus mode. Active in case ON/OFF DIP switch is off status. Ref: LGND
SVA	Standby Power	Output	5V provided for external use. Ref: LGND
OTW	Over-Temperature Warning	Output	Open drain FET; normally HI, changes to low approximately 5°C prior to thermal shutdown. Ref: LGND
Margin	Margining	Input	Allows changing of output voltage through an analog voltage input or via resistor divider. Active when ON/OFF switch is off status. Ref: LGND
Fault	Rectifier Fault	Output	And open drain FET; normally HI, changes to LOW if internal fault. Ref: LGND
LGND	Logic Ground	Bi-direct	Return for all signals unless V _{out} (-) is indicated in description
RS_485+	RS485 Line	Bi-direct	RS485 line + Ref: V _{out} (-)
RS_485-	RS485 Line	Bi-direct	RS485 line - Ref: V _{out} (-)
Ishare	Current Share	Bi-direct	A single wire active-current-share interconnect between rectifiers. Ref: V _{out} (-)
Enable_RS485	Output Control	Input	ON/OFF in RS485 mode. Ref: V _{out} (-)
Unit_addr	Rectifier Address	Input	I ² C/RS485 address setting. Ref: V _{out} (-)
BV_INT	Back Bias	Bi-direct	Diode OR'ed 8Vdc drain; used to back bias microprocessors and DSP of failed Rectifier from operating Rectifiers. Ref: V _{out} (-)
Protocol	Protocol Select	Input	Selects communications mode. No-connect for Analog/PMBus; 10k for RS485. Ref: V _{out} (-)
Shelf_addr	Shelf Address	Input	I ² C/RS485 address setting. Ref: V _{out} (-)
V _{out} (-)	Reference	Bi-direct	Ref for RS485 +/-, Ishare, Enable_RS485, Unit/Shelf addr, Protocol, 8V_INT, Protocol

All hardware alarm signals (Fault, PG, OTW) are open drain FETs. These signals need to be pulled HI to either 3.3V or 5V. Maximum sink current 5mA. An active LO signal (< 0.4V_{DC}) state. All signals are referenced to LGND unless otherwise stated.

Technical Specifications (continued)

In main output in series to extend V_o application, all signals refer to LGND from different units could be tied together. Other signals refer to V_{out} (-) from different units can NOT be tied together, otherwise may cause internal circuits damage due to different V_{out} (-) level.

DIP Switch and V_o Adjustment

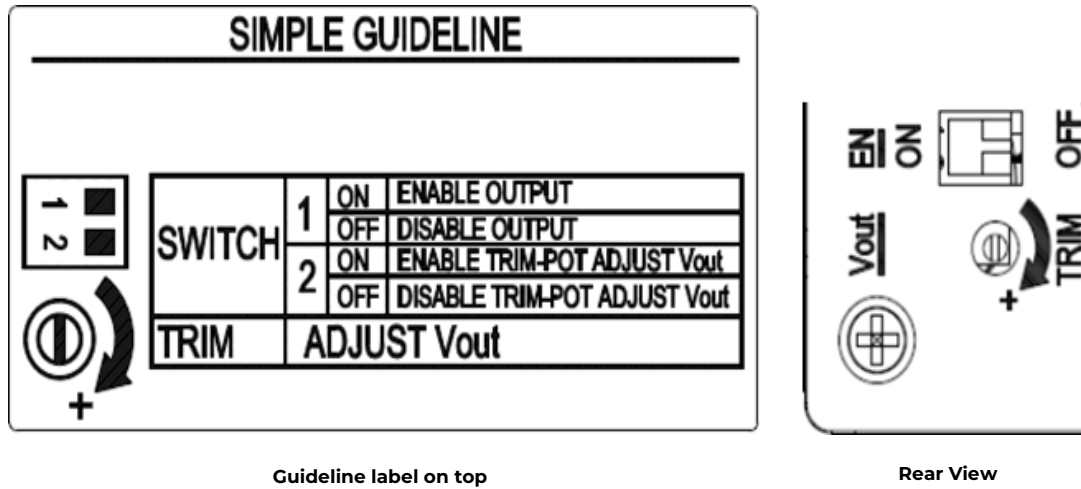

Mounting Dimensions

All dimensions are in mm

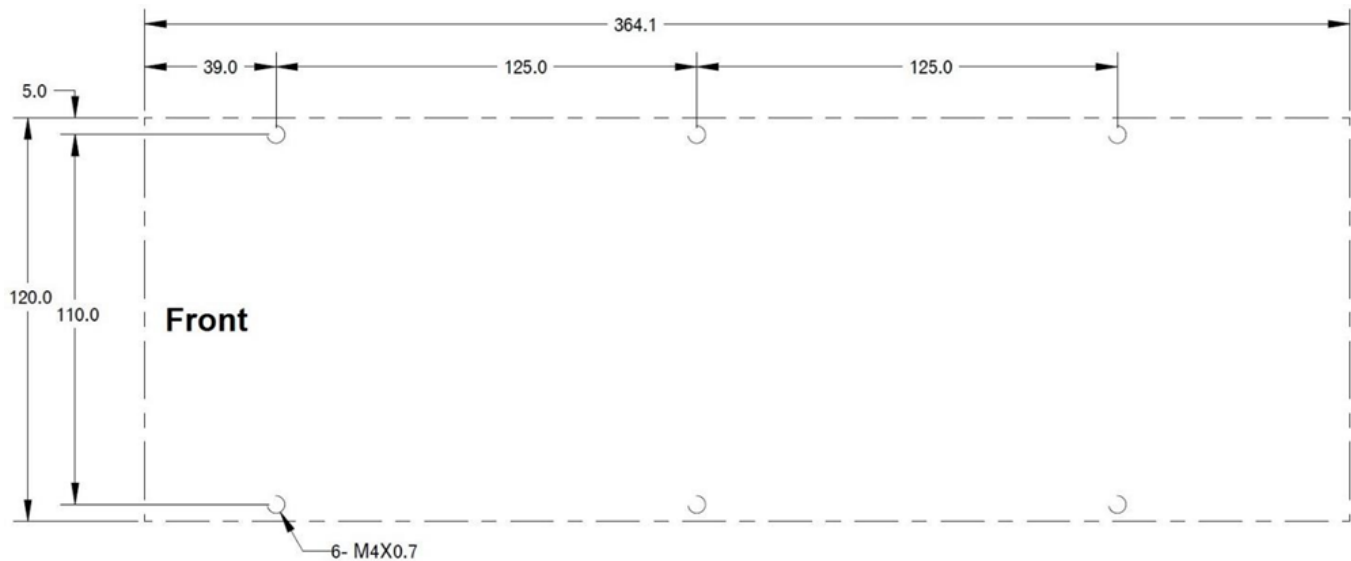

Technical Specifications (continued)

Mounting Diagram

Install the module to cold plate/heatsink with 6 M4 pan head screw as shown, the torque to be 1.5Nm. Apply gap filler, Laird T-putty 504, or equivalent material (thermal conductivity better than 1.8 W/mK), between module and cold plate/heatsink. Amount of Gap filler is around 20.9 cubic cm, thickness is around 0.5mm.

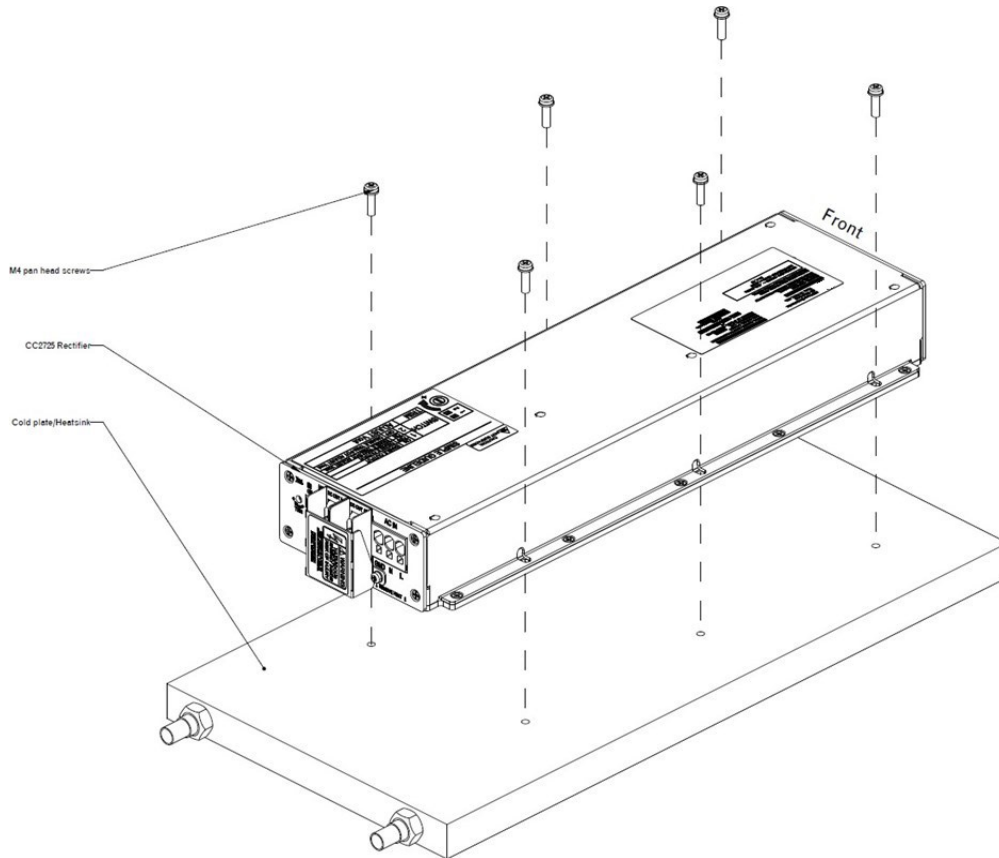

Case

Temperature Monitoring Location

Below diagram indicates the hot spots of CC2725AC34TZL rectifier, they are assumed as case temperature of cold plate/heatsink as well. In application, over temperature protection will be enabled if one of the hot spots the temperature is exceeded the operating temperature.

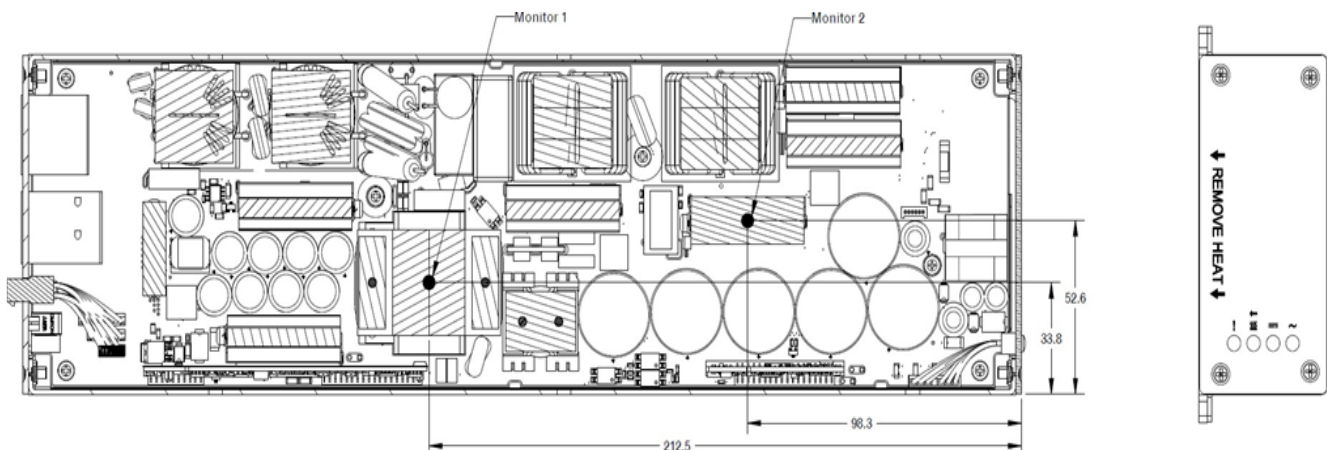

Technical Specifications (continued)

Ordering Information

Please contact your OmniOn Sales Representative for pricing, availability and optional features.

Item	Description	Ordering Codes
CC2725AC34TZL	Conduction cooled, 28~36V _{dc} output, shorter length rectifier, 2725W	1600281281A
Cable assembly	Wire set for signal I/O, 0.5m length	8600238857P

Change History (excludes grammar & clarifications)

Revision	Date	Description of the change
2.3	11/30/2021	Updated as per template
2.4	05/30/2023	Correction in electrical specification table on page – 2
2.5	11/02/2023	Updated as per OmniOn template

OmniOn Power Inc.

601 Shiloh Rd.
Plano, TX USA

omnionpower.com

We reserve the right to make technical changes or modify the contents of this document without prior notice. OmniOn Power does not accept any responsibility for errors or lack of information in this document and makes no warranty with respect to and assumes no liability as a result of any use of information in this document.

We reserve all rights in this document and in the subject matter and illustrations contained therein. Any reproduction, disclosure to third parties or utilization of its contents – in whole or in parts – is forbidden without prior written consent of OmniOn Power. This document does not convey license to any patent or any intellectual property right. Copyright© 2023 OmniOn Power Inc. All rights reserved.