

DATASHEET

CLP0212DC Open Frame Power Supply

48V_{DC} Input; 12V_{DC} Output; 200W Output Power



Description

Offering a leading 18W/in³ power density in a 1U high, fan-less form factor, the OmniOn Power™ CLP series addresses a broad range of applications in new products-from communications, computing and data storage for original equipment manufacturers (OEMs). It delivers greater than 90 percent typical power efficiency and full load output at +50°C(122°F) with higher temperature operation possible at derated

output. The CLP series utilizes a unique design approach at this power level, leveraging zero-voltage switching techniques. Protection features include overcurrent (CP), overvoltage (OVP), and overtemperature (OP). Applications include: Telecommunications Equipment | Embedded Computing | Storage Systems / Industrial Equipment In a small, 2x4-inch footprint, the 12Vdc single-output CLP0212DC open-frame power supply delivers high efficiency. With its small size, the CLP series is specifically designed to handle power challenges associated with tight space and low airflow.

Features

- Reverse input voltage protection
- Compact size 50.8 mm x 101.6 mm x 36.1 mm (2 in x 4 in x 1.4 in) with density of 18W/in³
- Universal DC Input Range (36 – 75V_{DC})
- Output voltage of 12V (adjustable ±5%)
- Maximum output current of 16.7A@ 12V_{out} (200W)
- Standby output of 5V @ 0.25A
- Full load capability at 50°C and 1m/s (200LFM) airflow with derating at higher temperatures or lower airflows
- Remote ON/OFF (ON if not connected)
- Output overcurrent protection (non-latching)
- Overtemperature protection
- Output overvoltage protection
- Up to 2ms of holdup time
- Parallelable with current sharing
- Conducted EMI - meets CISPR22 (EN55032) and FCC Class A requirements
- Compliant to RoHS Directive 2011/65/EU and amended Directive (EU) 2015/863.
- UL and cUL approved to UL/CSA62368-1, TUV (EN62368-1), CE Mark (for LVD) and CB Report available
- ISO** 9001 and ISO 14001 certified manufacturing facilities

Technical Specifications

Absolute Maximum Ratings

Stresses in excess of the absolute maximum ratings can cause permanent damage to the device. These are absolute stress ratings only, functional operation of the device is not implied at these or any other conditions in excess of those given in the operations sections of the Data Sheet. Exposure to absolute maximum ratings for extended periods can adversely affect device reliability.

Parameter	Device	Min	Max	Unit
Input Voltage - Continuous	All	36	75	V _{dc}
Operating Ambient Temperature	All	-40	85	°C
(in sealed enclosure applications with thermally conductive pad to enclosure, P _{O,max} = 110W)	All	-40	85 [†]	°C
Storage Temperature	All	-40	85	°C
Humidity (non-condensing)	All	5	95	%
Altitude	All		5000	m

[‡] Startup at -40°C is limited to 80% of maximum load (160W) for all versions.

^{*} Unit is capable of operation up to 85°C ambient for brief periods of time provided humidity is kept below 40%. Sustained operation at 85°C when power loading is at or near the maximum rated value can degrade reliability of the product.

[†] Ambient temperature outside the sealed enclosure containing the power supply.

Electrical Specifications

Parameter	Device	Min	Typ	Max	Unit
Operating Input Voltage	All	36	48	75	V _{dc}
Input Current	All			6.5	A _{dc}
Inrush Transient Current (T _{amb} = 25°C)	All			30	A _{peak}
Leakage Current to earth ground	All			2	mA
Output Voltage Setpoint	All		12		V _{dc}
Output Voltage Tolerance (due to set point, temperature variations, load and line regulation)	All	-2		2	%
Output Voltage Adjustment Range	All	11.4		12.6	V _{dc}
Output Remote Sense Range	All			250	mV _{dc}
Output Load Regulation	All			1.5	%V _{out}
Output Line Regulation	All			0.5	%V _{out}
Output Ripple and Noise – measured with 0.1µF ceramic capacitor in parallel with 10µF tantalum capacitor, at 25°C Peak-to-peak (20MHz Bandwidth)	All			180	mV _{p-p}
Dynamic Load Response – 50% to 75% load transient, 0.1A/µs slew rate					
Output voltage deviation	All			5%	%
Settling Time	All			500	µs
Output Current	All	0		16.7	A _{dc}
Output Current Limit Inception	All		115		% I _{O,max}
Maximum Output Capacitance	All			5000	µF
Standby Output Voltage	All		5		V _{dc}

OmniOn Power is a trademark of OmniOn Power Inc. All other trademarks belong to their respective owners.

Technical Specifications

Electrical Specifications (continued)

Parameter	Device	Min	Typ	Max	Unit
Standby Output Current	All			0.25	A _{dc}
Efficiency: V _{IN} = 48V _{dc} , 20% load	All	---	90.0	---	%
50% load		---	93.0	---	%
100% load		---	92.0	---	%
Holdup Time – 100% load (V _{out} ≥ 10.8V _{DC} , T _{amb} = 25°C, 200W, V _{IN} = full range)		2			ms

¹Output ripple is 300mV p-p maximum at -40°C. To reduce further, additional external capacitance needed.

Isolation Specifications

Parameter	Device	Min	Max	Unit
Isolation Voltage – Input to output	All		1000	V _{dc}

General Specifications

Parameter	Device	Symbol	Typ	Unit
Calculated Reliability based on Telcordia SR-332 Issue 2: Method 1 Case 3 (V _{IN} =48V _{dc} , I _o = 16.7A, T _A = 40°C, airflow200LFM, 90% confidence)	All	FIT MTBF	1,011.9 988,276	10 ⁹ /Hours Hours
Weight	All		185 6.5	g oz

Feature Specifications

Parameter	Device	Min	Typ	Max	Unit
On/Off Signal Interface – signal referenced to GND					
Logic Low (Power Supply ON)	All			7	mA
Input Low Current				1	V
Input Low Voltage	All				
Logic High (Power Supply OFF)	All			600	μA
Input High Current				5.5	V
Input Voltage	All				
Delay from ON/OFF being enabled to start of output voltage rise	All			50	ms
Output Voltage Rise Time (from 10 to 90% of final value)	All		5		ms
Delay from Input being applied to standby output being in regulation	All		2		s
Delay from Input being applied to all outputs being in regulation	All		2		s
Output Overvoltage Protection (for main output currents above 0.1A)	All	13.8		18	V _{dc}
Input Undervoltage lockout ³	All				
Turn-on Threshold (100% load)		33	35	36	V _{dc}
Turn-off Threshold (100% load)					
DC OK – open collector, High when output available					
Sink Current	All			4	mA
Maximum Collector Voltage	All			12	V

² Holdup time is reduced at cold temperatures

³ The undervoltage lockout thresholds vary with output load current level – decreasing as the load goes down

Technical Specifications (continued)

Environmental Specifications

Parameter	Device	Specification
Conducted Emissions	All	CISPR22 (EN55032) Class B with 3dB margin
Input Harmonics	All	EN61000-3-2
ESD	All	IEC 61000-4-2, Level 3
Radiated Immunity	All	CISPR22 (EN55032) Class B with 3dB margin
Electrical Fast Transient Common Mode	All	IEC 61000-4-4, Level 3
Surge Immunity	All	IEC 61000-4-5; $\pm 1\text{kV}$ common mode and differential mode, unit passes criteria A (normal performance; impedance is 2 Ohms for differential and common mode.) $\pm 2\text{kV}$ common mode (impedance 12Ohms), unit passes criteria A.
Conducted RF Immunity	All	IEC 61000-4-6, Level 3
Voltage Dips, Interruptions	All	-53Vin, 80% load, Dip 100% duration 4ms, Criteria (A)
Shock and Vibration		
Operating Shock	All	Three shocks, 15G peak, 11ms sine wave, two axes
Non-Operating Shock	All	Three shocks, 50G peak, 11ms sine wave, two axes
Operating and Non-Operating Vibration	All	5 – 9Hz, 0.5" double amplitude, 2G Peak, 0.5 oct./min., 2 cycles 9-500Hz, 4G pk-pk, 0.5 oct/min., 2 cycles

Technical Specifications (continued)

Power Derating for Forced Air Flow Application

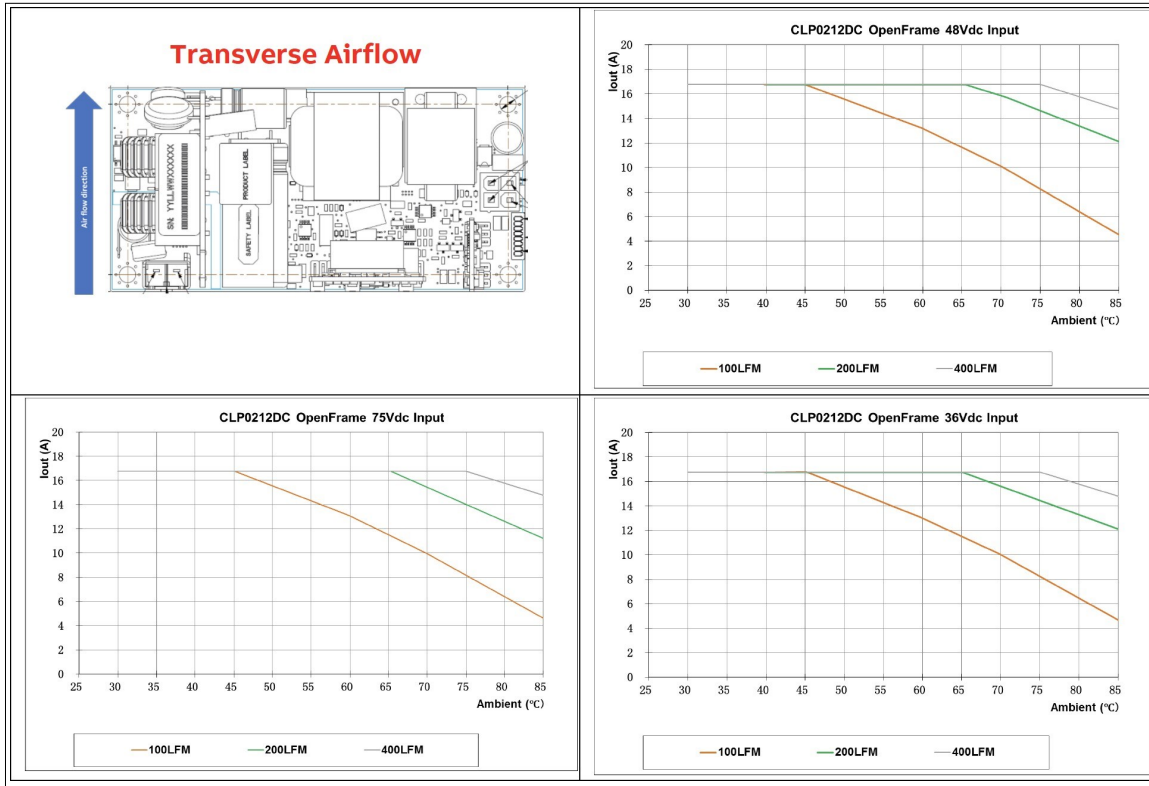

Derating under transverse airflow for various input voltages.

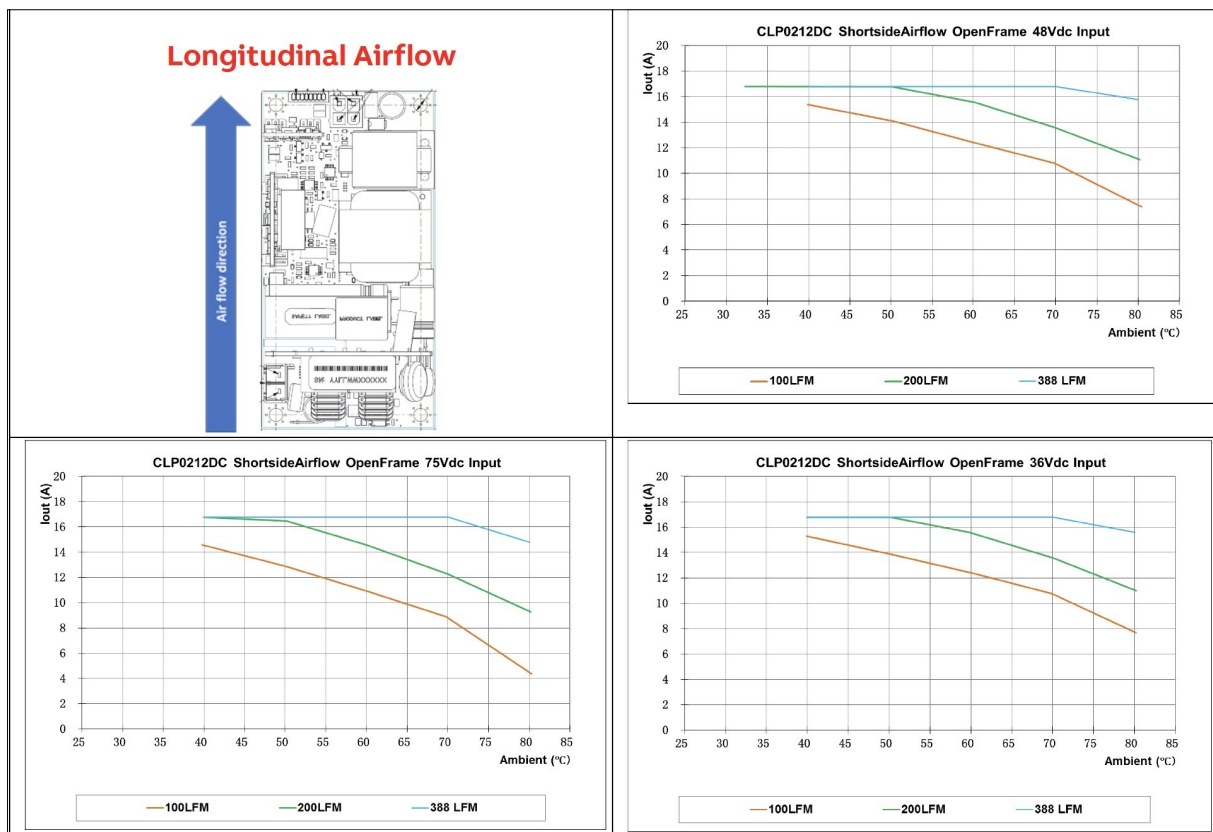

Derating under longitudinal airflow for various input voltages.

Technical Specifications (continued)

Safety Considerations

The CLP0212DC power supply is intended for inclusion in other equipment and the installer must ensure that it is in compliance with all the requirements of the end application. This product is only for inclusion by professional installers within other equipment and must not be operated as a stand-alone product. The power supply meets Class 1, ANSI/UL* 62368-1 and CAN/CSA† C22.2 No. 62368-1 Recognized, DIN VDE‡ 0868-1/AT1:2017 (EN62368 -1:2014/AT1:2017)

Feature Descriptions

Standby Power Supply

A standby output in the CLP0212DC power supply of 5V, comes on when DC input in the operating range is applied.

Remote On/Off

The CLP0212DC power supply features a TTL-compatible On/Off control input. The power supply turns ON when the On/Off input goes low, and turns OFF when the input goes high. Note that if the On/Off pin is left unconnected, the power supply main output will turn ON when DC input is present.

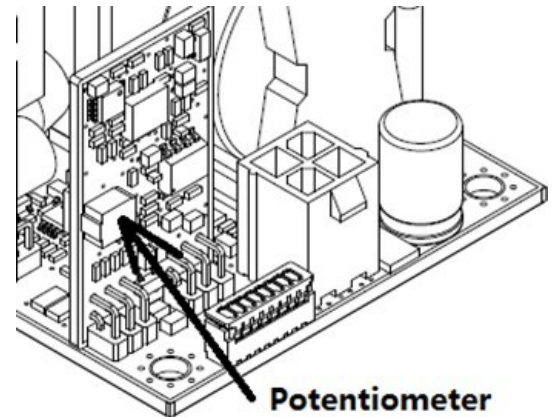

Fig. 10. Diagram showing location of the potentiometer used to adjust the power supply output voltage.

Output Voltage Adjustment

The output voltage can be adjusted between 11.4V and 12.6V using a potentiometer on the power supply. See Fig. 10 for a diagram showing location of the potentiometer.

Remote Sense

The power supply has both positive and negative remote sense connections that can be connected to the positive and negative rails of the main output near the load. Care should be taken in routing the sense lines to ensure that noise is not picked up or that additional filtering elements that affect the stability of the power supply are not used. The power supply will operate without the remote sense connections being made, however if remote sense near the load is not used it is recommended that the remote sense lines be connected directly to the main output terminals.

Overcurrent Protection

To provide protection in a fault condition (output overload), the power supply is equipped with internal current-limiting circuitry and can endure current limiting continuously. At the point of current-limit inception, the unit enters hiccup mode. The power supply operates normally once the output current is brought back into its specified range.

Overvoltage Protection

Overvoltage protection is a feature of the CLP0212DC power supply that protects both the load and the power supply from an output overvoltage condition. When an overvoltage occurs, the power supply shuts down and goes into hiccup mode until the overvoltage condition is removed. It is not necessary to recycle the input to restart the power supply when this protection is activated.

Technical Specifications (continued)

Reverse Input Voltage Protection

Reverse Input Voltage Protection is a feature of the CLP0212DC power supply that protects the power supply from damage if a reverse voltage is applied to the input.

Overtemperature Protection

The CLP0212DC also features overtemperature protection in order to provide additional protection in a fault condition. The power supply is equipped with a thermal shutdown circuit which detects excessive internal temperatures and shuts the unit down. Once the power supply goes into overtemperature shutdown, it will cool before at-tempting to restart. The overtemperature protection circuit will typically activate when the unit is operated at 200W output with an ambient temperature of 60°C and 1m/s (200LFM) airflow.

Input Undervoltage Lockout

At input voltages below the input undervoltage lockout limit, power supply operation is disabled. The power supply will begin to operate at an input voltage above the undervoltage lockout turn-on threshold. Note that the undervoltage lockout limits are load dependent and the power supply turns ON and can operate at much lower input voltage levels when at light or no load.

DC OK

The CLP0212DC provides a DC OK signal that indicates when the output has come up and is in regulation. This is an open-collector type signal that goes high when the output is available and within regulation.

Power Good LED

A green LED (located next to HDR3) illuminates when the main output voltage is above 10V.

Paralleling/Load Share

This power supply can be paralleled to provide larger load currents than can be delivered from a single power supply. Up to four power supplies may be paralleled. Paralleling is accomplished by connecting the Current Share signals of multiple power supplies together. At load current levels above 20%, the output currents of multiple power supplies will be within $\pm 5\%$ of the full load value.

If remote sense is used when paralleling is employed, the remote sense connection points should be common to both power supplies.

For applications where redundancy among paralleled power supplies is desired, ORing diodes or other active ORing circuitry needs to be connected in series with each output.

Thermal Considerations

The power supply can be operated in a variety of thermal environments; however sufficient cooling should be provided to ensure reliable operation.

Considerations include ambient temperature, airflow, power supply dissipation and the need for increased reliability. A reduction in the operating temperature of the power supply will result in increased reliability. The thermal data presented here is based on measurements taken in a wind tunnel.

Heat Transfer via Convection

Increased airflow through the power supply enhances the heat transfer via convection. Figure 11 shows the preferred airflow direction. Contact your OmniOn Energy technical representative for derating information in other airflow directions.

Note: Under Natural Convection cooling conditions, the maximum load is restricted to 100W as OTP will be triggered at higher loads.

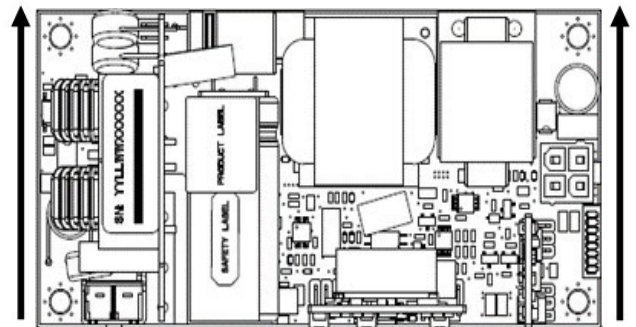

Fig. 11. Preferred airflow direction for cooling.

Operation in a Sealed Enclosure

The CLP0212DC power supply can also be operated in a sealed enclosure provided proper means for removing heat from the power supply are used. Figure 12 shows an arrangement where a thermally conductive pad is used to transfer heat from the bottom of the power supply into the enclosure. Under such conditions, the power supply is capable of reduced power operation as shown in Table 1. Note that the Ambient Temperature shown in Table 1 is that outside the sealed enclosure, the CLP0212DC may see higher ambient temperatures.

Technical Specifications (continued)

Operation in a Sealed Enclosure (continued)

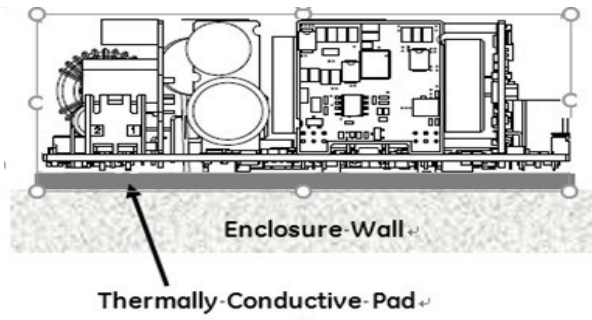

Fig. 12. Example arrangement of the CLP0212DC for sealed enclosure applications.

Enclosure Outside Surface (°C)	Enclosure Inside Ambient (°C)	Resistive Load (W) on CLP0212DC
50	85	200
55	92	190

Table 1. Output Power Capability when the CLP0212DC is operated in a sealed enclosure with thermal pad for conduction cooling. (Enclosure Application; With 200W resistive load inside enclosure.)

Note: The enclosure outside ambient temperature measured at 2 inches above enclosure.

Technical Specifications (continued)

Mechanical Outline (CLP0212DC)

Dimensions are in millimeters.

Tolerances: x.x mm ± 0.5mm [unless otherwise indicated] / x.xx mm ± 0.25mm

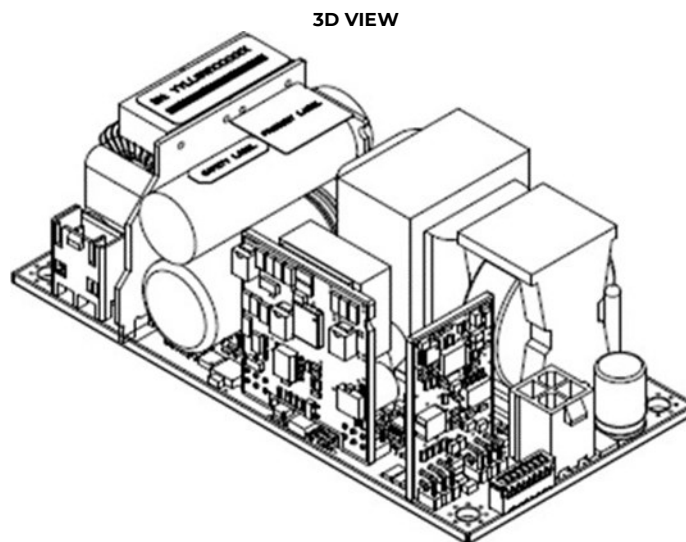
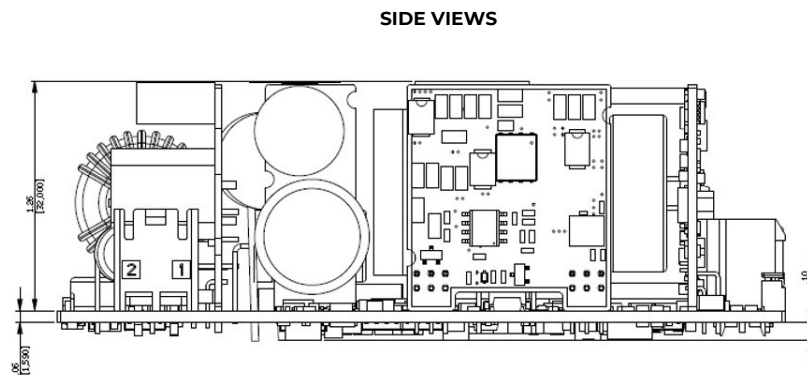
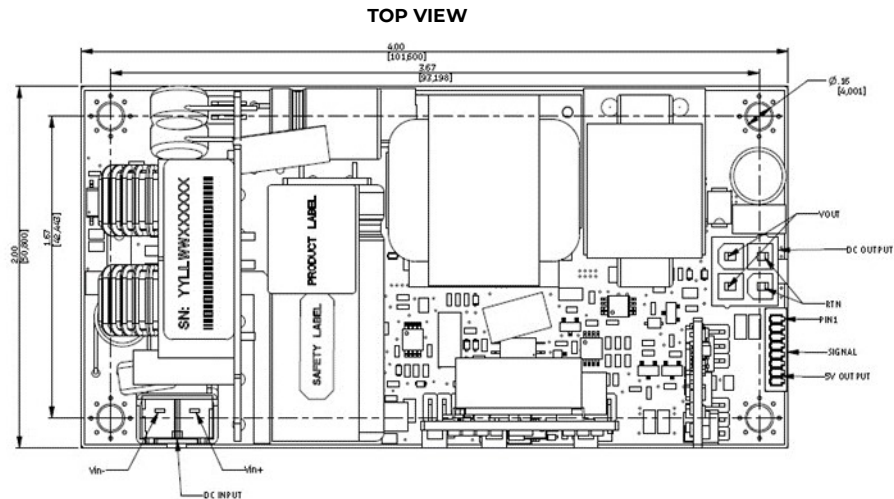

Technical Specifications (continued)

Connector Information

Connector	Device	Min
DC Input Connector (HDR1)	5-1376382-1 from Tyco or equivalent	1376388-1 from Tyco or equivalent
DC Output Connector (HDR2)	39-28-1043 from Molex or equivalent	-39-01-2040 from Molex or equivalent
Signal Connector** (HDR3)	10114829-13108LF from Amphenol or equivalent	10114826-00008LF Housing from Amphenol or equivalent 10114827-004LF Mating pin from Amphenol or equivalent

Pinout Information

DC Input Connector (HDR1)		DC Output Connector (HDR2)		Signal Connector (HDR3)	
Pin 1	Line	Pin 1	VO	Pin 1	Current Sense
Pin 2	Neutral	Pin 2	VO	Pin 2	+S (Remote Sense +)
		Pin 3	RTN	Pin 3	-S (Remote Sense -)
		Pin 4	RTN	Pin 4	Remote On/Off
				Pin 5	DC-OK (Output OK)
				Pin 6	COM (Output Return)
				Pin 7	COM (Output Return)
				Pin 8	Standby Output

Ordering Information

Device Code	Input Voltage Range	Output Voltage	Output Current	On/Off Control	Standby Supply	Temperature Range	Ordering Codes
CLP0212DCS X5Z01C	36 – 75V _{dc}	12.0V _{dc}	16.7A	Negative Logic	5V@0.25A	-40 to 85°C	CLP0212DCSX5Z01C

Change History (excludes grammar & clarifications)

Revision	Date	Description of the change
4.3	12/10/2021	Updated as per template
4.4	05/30/2023	Correction in electrical specification table on page – 2
4.5	11/01/2023	Updated as per OmniOn template
4.6	10/02/2024	Updated Trademark information. Data updates on pages 1, 2 (inrush), 4 (surge immunity), 6 (remote sense), 9 (side view)

OmniOn Power Inc.

601 Shiloh Rd.
Plano, TX USA

omnionpower.com

We reserve the right to make technical changes or modify the contents of this document without prior notice. OmniOn Power does not accept any responsibility for errors or lack of information in this document and makes no warranty with respect to and assumes no liability as a result of any use of information in this document.

We reserve all rights in this document and in the subject matter and illustrations contained therein. Any reproduction, disclosure to third parties or utilization of its contents – in whole or in parts – is forbidden without prior written consent of OmniOn Power. This document does not convey license to any patent or any intellectual property right. Copyright© 2023 OmniOn Power Inc. All rights reserved.