

DATASHEET

CLP0224FPHVXZ04A Open Frame Power Supply

360 to 528 Vac Input; 24V/8.3A Output; 200W Output Power



In a small 2.6 x 5 inch footprint, the 24 Vdc single output , high voltage input CLP0224 open frame power supply delivers 89% typical power efficiency. With its compact size, the CLP series is specifically designed to handle power challenges associated with tight space. Protection features include overcurrent (OCP), overvoltage (OVP), and overtemperature (OTP).

Applications

High voltage input (380-528VAC) to 24VDC output conduction cooled rectifier for loads up to 200W. The CLP0224FPHV rectifier is designed for fan-less industrial applications in low power / low voltage control, housekeeping, test, and measurement requiring 24VDC use voltage.

Features

- Compact size 66 mm x 127 mm x 44.5 mm (2.6 in x 5 in x 1.75 in)
- AC Input Range (360 – 528VAC)
- Output voltage of 24VDC (no adjust)
- No Airflow operation
- Cold plate temps of 20 to 30degC
- Maximum output current of 8.3A @ 24Vout (200W)
- Efficiency of 89% at 100% load
- Conformal coated
- Output overcurrent protection (non-latching)
- Overtemperature protection
- Output overvoltage protection
- Up to 10ms of holdup time
- Conducted EMI - meets CISPR22 (EN55022)and FCC Class A requirements
- Compliant to RoHS II EU "Directive 2011/65/EU"
- Ambient temperature operating range -10deg to 50degC

Technical Specifications

Absolute Maximum Ratings

Stresses in excess of the absolute maximum ratings can cause permanent damage to the device. These are absolute stress ratings only, functional operation of the device is not implied at these or any other conditions in excess of those given in the operations sections of the data sheet. Exposure to absolute maximum ratings for extended periods can adversely affect the device reliability.

Parameter	Device	Min	Max	Unit
Input Voltage - Continuous	All	360	528	Vac
Operating Ambient Temperature (see Thermal Considerations section)	All	-10	50	°C
Storage Temperature	All	-40	85	°C
Humidity (non-condensing)	All	5	95	%
Altitude	All		2000	m
Isolation Voltage – Input to output	All		3000	Vac
Input to safety ground	All		1500	Vac
Outputs to safety	All		50	Vac

Electrical Specifications

Parameter	Device	Min	Typ	Max	Unit
Operating Input Voltage	All	360	480	528	Vac
Input Source Frequency	All	47	50/60	63	Hz
Input Current	All			2	A
Maximum Inrush Current (VIN = 528Vac, Tamb = 25°C)	All			50	A Peak
Leakage Current to earth ground (VIN = 528Vac)	All			3.5	mA
Output Voltage Setpoint	All		24		Vdc
Output Voltage Tolerance (due to set point, temperature variations, load and line regulation)	All	-3		3	%
Output Voltage Adjustment Range	All	23.28		24.72	Vdc
Output Ripple and Noise – measured with 0.1µF ceramic capacitor in parallel with 10µF tantalum capacitor ¹ Peak-to-peak (20MHz Bandwidth)	All			360	mVp-p
Dynamic Load Response – 50% to 100% load transient, 1A/µs slew rate	All			5%	%
Output voltage deviation	All			500	µs
Settling Time					
Output Current	All	0		8.33	Adc
Output Current Limit Inception	All	110		170	% IO,max
Maximum Output Capacitance	All			3000	µF
Efficiency: VIN = 48Vdc, 20% load	All		84		%
50% load	All		88		%
100% load	All		89		%
Holdup Time – 100% load ² (Vout ≥ 21.6VDC, Tamb = 25°C, 200W, VIN = full range)	All	10			ms

Technical Specifications (continued)

General Specifications

Parameter	Device	Symbol	Typ	Unit
Calculated Reliability based on Telcordia SR-332 Issue 3: Method 1 Case 3 (VIN=480Vac, I _o = 8.3A, TA = 40°C, without conductive cool airflow, 90% confidence)	All	MTBF	>2,500,000	Hours
Weight	All		245 8.64	g oz.

Feature Specifications

Parameter	Device	Min	Typ	Max	Unit
Output Voltage Rise Time (from 10 to 90% of final value)	All			30	ms
Delay from Input being applied to all outputs being in regulation	All			3000	s
Output Overvoltage Protection	All			35	Vdc
Input Undervoltage lockout ³					
Turn-on Threshold (100% load)	All		230		Vac
Turn-off Threshold (100% load)	All		200		Vac

Safety Specifications

Parameter	Device	Specification
Dielectric Withstand Voltage (between input and output)	All	Minimum of 3000Vac
Safety Standards	All	CB report to IEC61010-1 or IEC62477-1

Environmental Specifications

Parameter	Device	Specification
Radiated Emissions ⁴	All	CISPR22 (EN55022) Class A with 3dB margin
Conducted Emissions	All	CISPR22 (EN55022) Class A with 3dB margin
ESD	All	IEC61000-4-2, Level 3
Radiated Susceptibility ⁴	All	IEC61000-4-3, Level 2
Electrical Fast Transient Common Mode	All	IEC61000-4-4, Level 3
Surge Immunity	All	IEC 61000-4-5, Level 3 common mode and differential mode, unit passes criteria A (normal performance; impedance is 2 Ohms for differential and common mode.)
Conducted RF Immunity	All	IEC61000-4-6, Level 3
Voltage Dips, Interruptions	All	EN 61000-4-11, Output stays within regulation for 1/2 cycles
Shock and Vibration	All	Per IPC-9592B
Qualification Testing Standard	All	Per IPC-9592B, Class II

¹ Output ripple specification is met over -10 to 50°C

² Holdup time is reduced at cold temperatures

³ Undervoltage lockout threshold may vary with output load current level – decreasing as load goes lower

⁴ Test with metal enclosure

Technical Specifications (continued)

Characteristic Curves

The following figures provide typical characteristics for the CLP0224FPHV power supply.

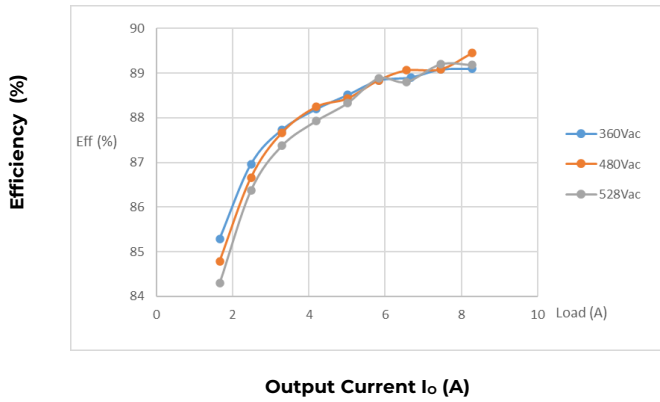

Figure 1. Power Supply Efficiency Versus Output Current

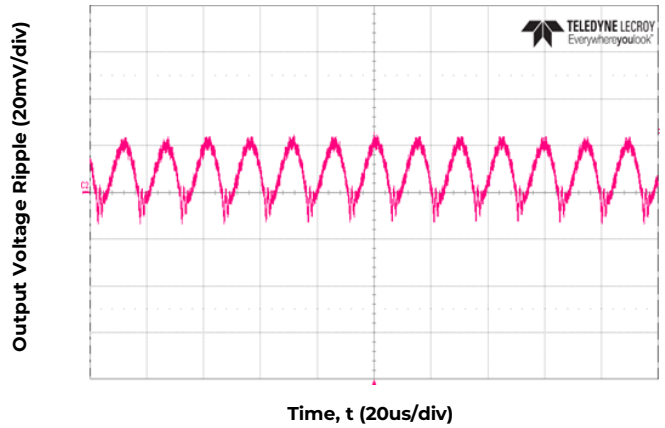

Figure 2. Typical output ripple and noise ($V_{IN} = 480V_{ac}$ 100%)

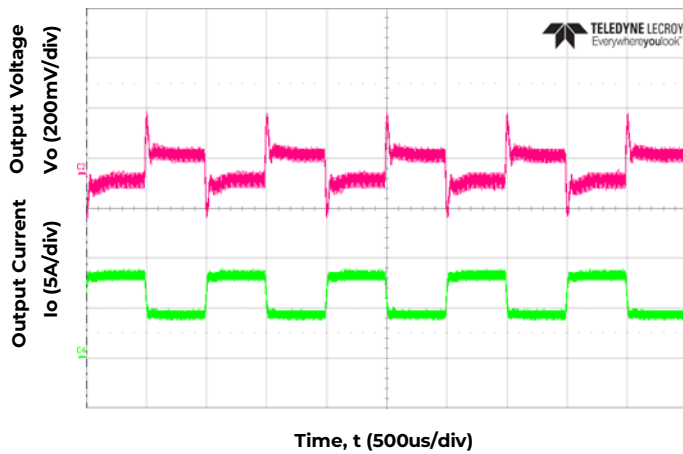

Figure 3. Transient Response to Dynamic Load change from 50% to 100% at $V_{IN}=480V_{ac}$, 25C, 1A/us Slew Rate

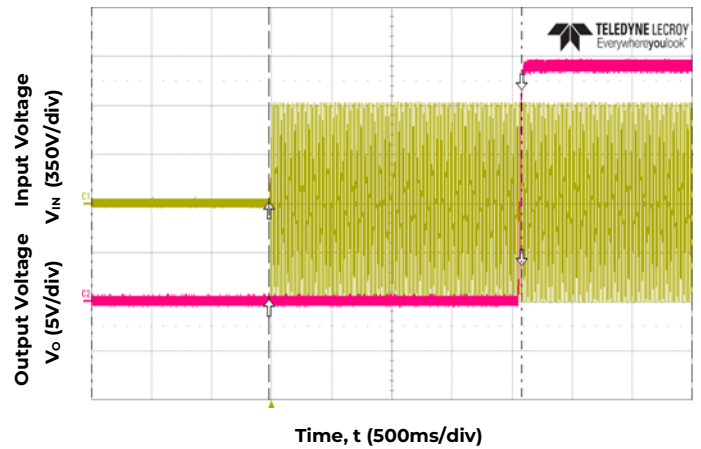

Figure 4. Typical Start-up ($V_{IN}=480V_{ac}$, Full Load@25°C)

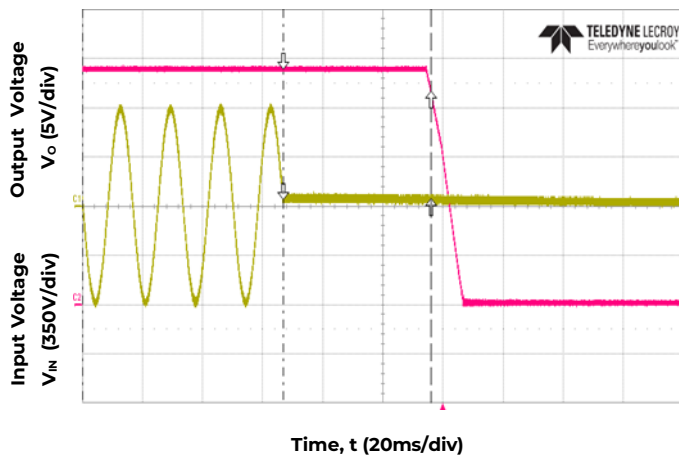

Figure 5. Typical Hold-up waveforms ($V_{IN}=480V_{ac}$, 100% Load@25°C)

Technical Specifications (continued)

Safety Considerations

The CLP0224FPHV embedded power supply is designed for integration into an end product and shall be installed in compliance with the enclosure, mounting, spacing, casualty and segregation requirements of the end-use application. A suitable Electrical and Fire enclosure shall be provided and is not intended to be operated as a stand-alone product. A CB report to IEC61010-1 or IEC62477-1.

Feature Descriptions

Overcurrent Protection

To provide protection in a fault condition (output overload), the power supply is equipped with internal current-limiting circuitry and can endure current limiting continuously. At the point of current-limit inception, the unit enters hiccup mode. The power supply operates normally once the output current is brought back into its specified range.

Overvoltage Protection

Overvoltage protection is a feature of the CLP0224FPHV power supply that protects both the load and the power supply from an output over-voltage condition. When an overvoltage occurs, the power supply shuts down and latches off until the overvoltage condition is removed. It is necessary to recycle the input to restart the power supply when this protection is activated.

Overtemperature Protection

The CLP0224FPHV also features overtemperature to provide additional protection in a fault condition. The power supply is equipped with a thermal shutdown circuit which detects excessive internal temperatures and shuts the unit down. Once the power supply goes into overtemperature shutdown, it will cool before attempting to restart.

Input Undervoltage Lockout

At input voltages below the input undervoltage lockout limit, power supply operation is disabled. The power supply will begin to operate at an input voltage above the undervoltage lockout turn-on threshold. Note that the undervoltage lockout limits are load dependent and the power supply turns ON and can operate at much lower input voltage levels when at light or no load.

Output Voltage Adjustment

None.

Power Good LED

A green LED on board the power supply illuminates when the main out-put voltage is above 20V.

Assembling

Please use metal screws to mount the unit and make sure the 4 mounting holes are connected to Earth well.

Operation in a Sealed Enclosure

The power supply can also be operated in a sealed enclosure or in an environment where cooling is primarily via conduction. Figure 1 shows an arrangement where thermally conductive pads are used to transfer heat from the top and bottom of the power supply into the enclosure.

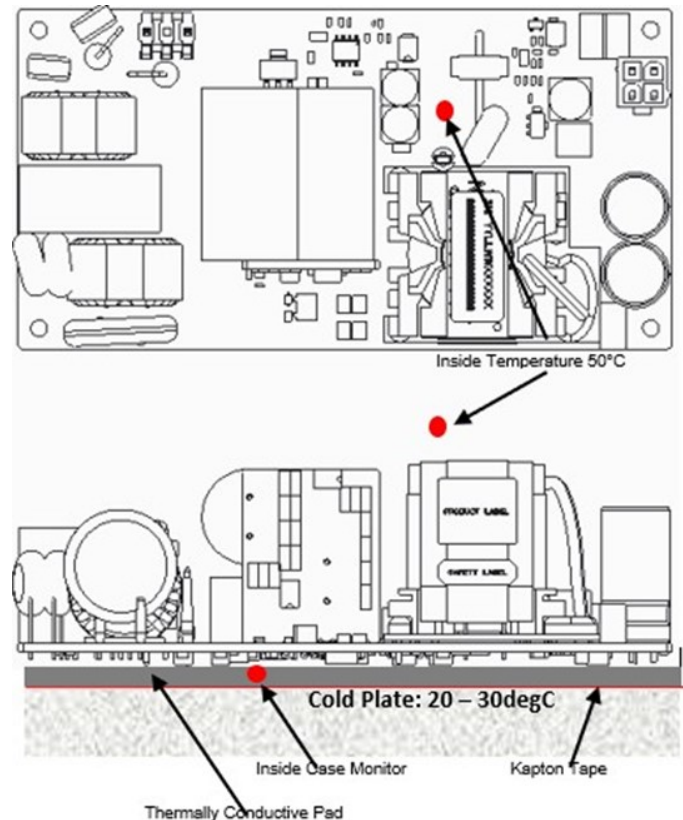
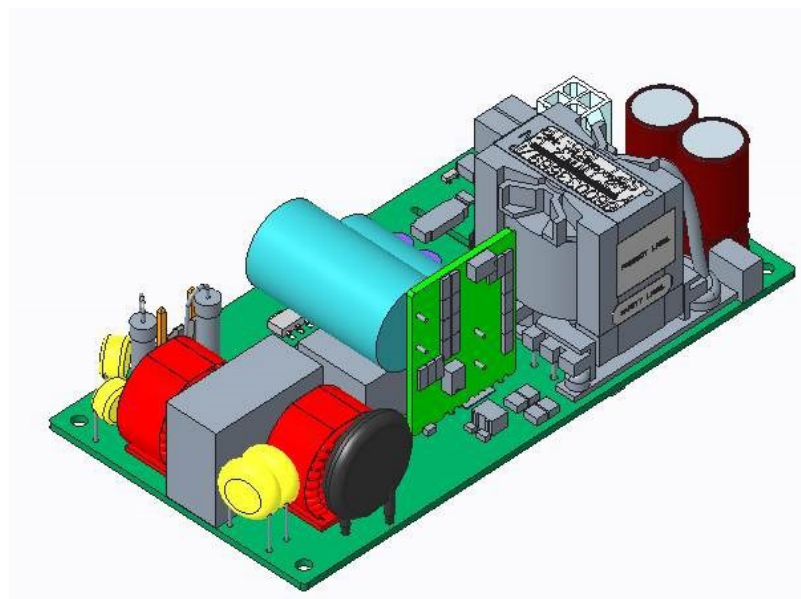
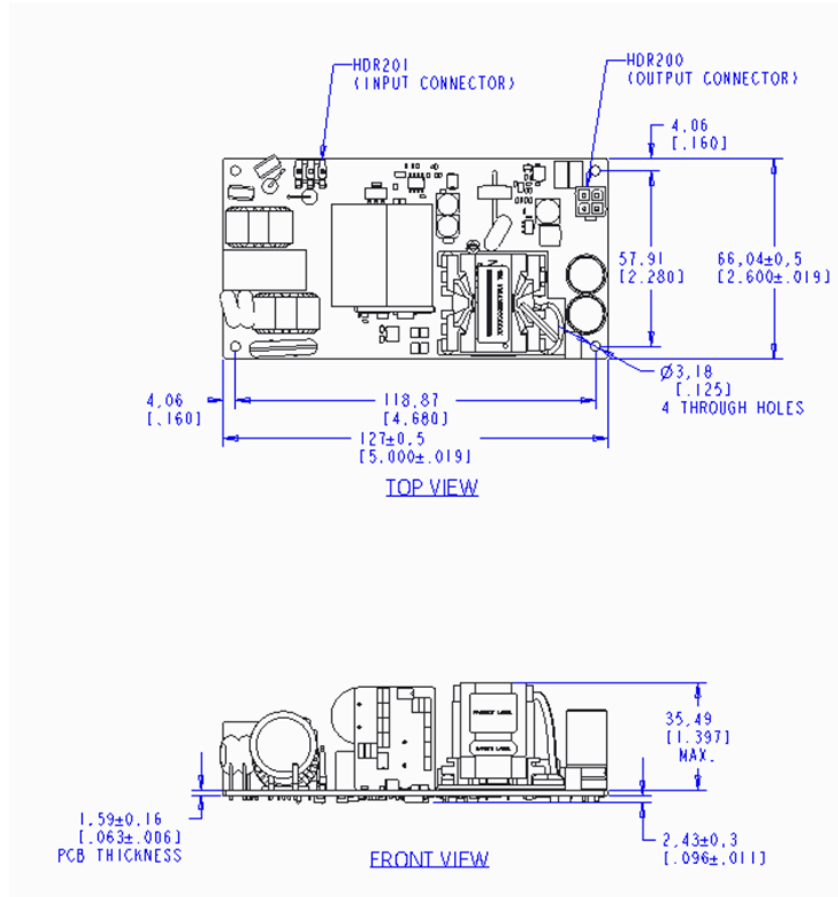

Fig. 6. Arrangement of the CLP0224FPHVXZ04A in application, the Cold Plate will be held between 20°C to 30°C

Technical Specifications (continued)

Mechanical Outline



Technical Specifications (continued)

Connector Information

Connector	Connector on Power Supply	Mating Connector
AC Input Connector (HDR201)	Molex 26-50-3030 or equivalent	Molex Housing 09-50-8031 or equivalent Molex Terminal 0008500106 or equivalent
DC Output Connector (HDR200)	Molex 39-28-8040 or equivalent	Molex Housing 39-01-2045 or equivalent Molex Terminal 39-00-0077 or equivalent

Pinout Information

Connector		DC Output Connector	
PIN 1	Line	PIN 1, 2	VOUT +
PIN 3	Line	PIN 3, 4	GND

Ordering Information

Device Code	Input Voltage Range	Output Voltage	Output Current	Temperature Range	Intended Application	Ordering code
CLP0224FPHV XZ04A (Conformal Coated)	360 – 528Vac	24.0Vdc	8.3A	-10 to 50°C	Industrial	CLP0224FPHV XZ04A

OmniOn Power Inc.

601 Shiloh Rd.
Plano, TX USA

omnionpower.com

We reserve the right to make technical changes or modify the contents of this document without prior notice. OmniOn Power does not accept any responsibility for errors or lack of information in this document and makes no warranty with respect to and assumes no liability as a result of any use of information in this document.

We reserve all rights in this document and in the subject matter and illustrations contained therein. Any reproduction, disclosure to third parties or utilization of its contents – in whole or in parts – is forbidden without prior written consent of OmniOn Power. This document does not convey license to any patent or any intellectual property right. Copyright© 2023 OmniOn Power Inc. All rights reserved.