

DATASHEET

IND065BLV Hornet: Non-Isolated DC-DC Voltage Regulator Modules

12V_{dc} input; 16V_{dc} to 34V_{dc} output; 65W Max Power

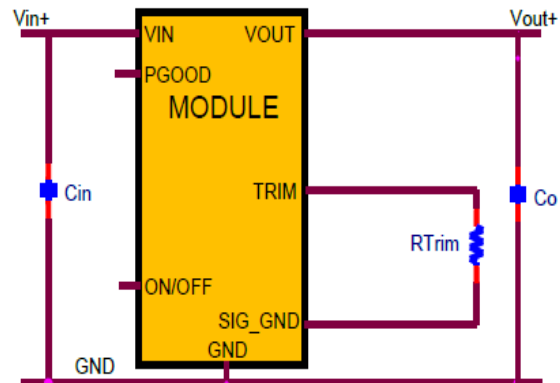

Applications

- Industrial Equipment
- Control Boards
- Test Equipment

Electrical Features

- 12V ($\pm 20\%$) Input voltage
- Output voltage programmable from 16V_{dc} to 34V_{dc} via external resistor
- Remote On/Off for optional external control
- Fixed switching frequency
- Output overcurrent protection (non-latching)

Mechanical Features

- Small size: 27.9 mm x 11.4 mm x 8.5 mm (1.1 in x 0.45 in x 0.335 in)
- Operating range: -40°C to 85°C ambient

Process and Safety

- Qualified for 1000h High Temperature Operating Bias, 1000h 85RH/85°C Temperature, Humidity and Bias, 700 cycle -40 to 125°C thermal cycling.
- ANSI/UL* 62368-1 and CAN/CSA† C22.2 No. 62368-1 Recognized, DIN VDE‡ 0868-1/A11:2017 (EN62368-1:2014/A11:2017)
- ISO** 9001 and ISO 14001 certified manufacturing facilities
- Compliant to RoHS Directive 2011/65/EU and amended Directive (EU) 2015/863
- Compliant to REACH Directive (EC) No 1907/2006
- Compatible in a Pb-free or SnPb reflow environment.
- Suitable for aqueous clean.
- Suitable for conformal coating with dip and vapor deposition. Conformal coating can provide the protection to meet Salt. Fog Test per IEC 60068-2-52 (Severity 3) and Mixed Gas Flow test per Telcordia GR-3108 Outdoor Levels.
- 3 year warranty

Technical Specification

Process and Safety (continued)

| Device Code | Input Voltage | Output Voltage | Output Current (Max.) | On/Off Logic | Ordering Code |
|-------------|---------------------------|------------------------|-----------------------|--------------|---------------|
| IND065BLV | 9.6 – 14.4V _{dc} | 16 – 34V _{dc} | 4.06(@16V) | Negative | 1600102911A |

Thermal Performance

Full rated output with natural convection up to 69°C at 16V_{out} and up to 54°C at 34V_{out}. Thermal curves for 3 Voltage below.

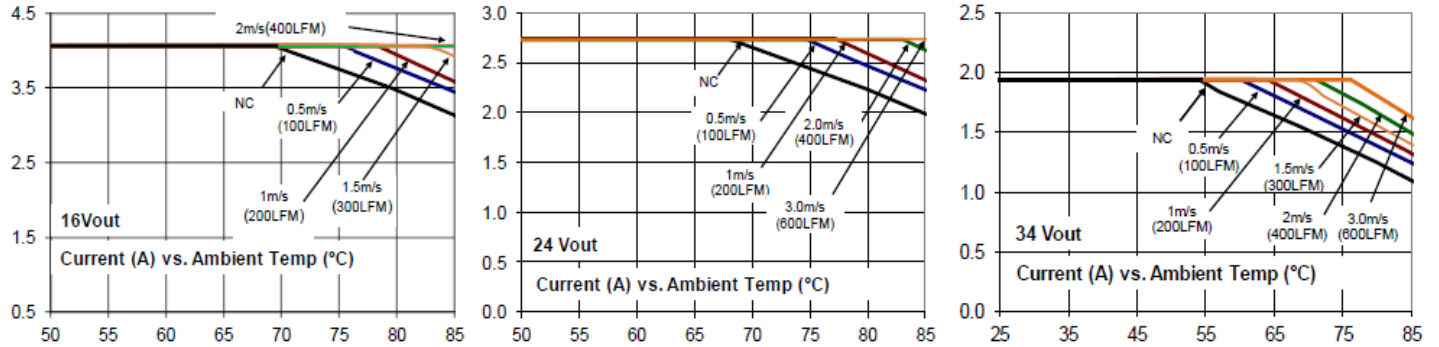

Heat Transfer via Conduction

The module can also be used in a sealed environment with cooling via conduction from the module's top surface through a gap pad material to a cold wall, as shown below. The output current derating versus cold wall temperature, when using a thermal pad and a gap filler is shown below.

Thermal pad: Bergquist P/N: GP2500S20
Gap filler: Bergquist P/N: GF2000

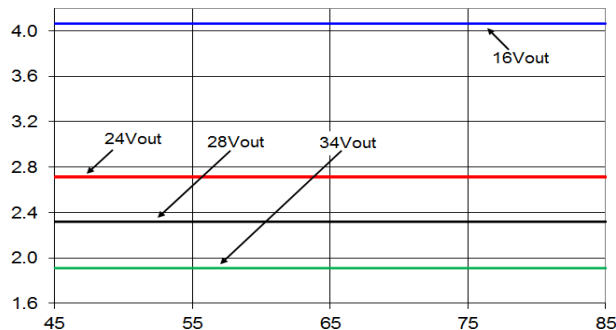
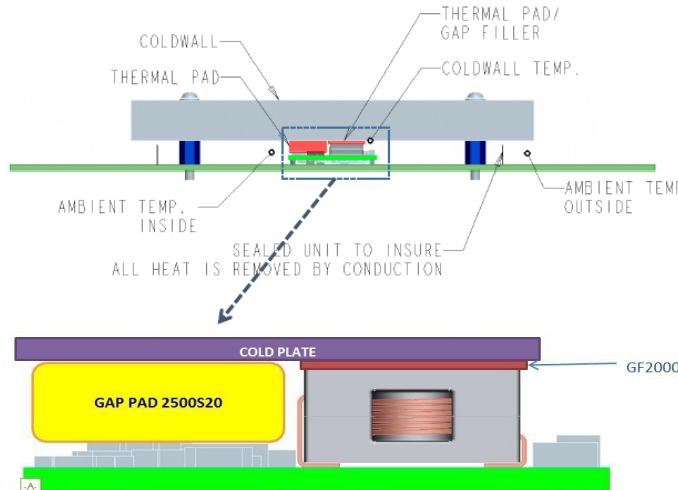

Figure 1. Output Current versus Coldwall Temperature;

V_{IN} = 12V

Technical Specification (continued)

Electrical Specifications

| Parameter | Device | Symbol | Min | Typ | Max | Unit |
|--|------------------------|-------------------|--|-------|------|---------------|
| Operating Input Voltage | All | V_{IN} | 9.6 | 12 | 14.4 | V_{dc} |
| Input No Load Current ($V_{IN} = 12.0V_{dc}$, $I_o = 0$, module enabled) | $V_{O,set} = 16V_{dc}$ | $I_{IN,No\ load}$ | | | 32 | mA |
| | $V_{O,set} = 34V_{dc}$ | $I_{IN,No\ load}$ | | | 110 | mA |
| External Capacitance, Ceramic ESR $\geq 1\ m\Omega$ | All | $C_{O,max}$ | 10 | - | 100* | μF |
| Output Current | All | I_o | 4.06(16V), 2.71(24V), 2.32(28V), 1.91(34V) | | | A |
| Efficiency 12VINDC, TA=25°C, I=12A, Vo=32 to 34Vdc | | η | 96(16V), 94.5(24V), 94(28V) | | | % |
| Switching Frequency | All | f_{sw} | - | 332 | - | kHz |
| Output Voltage (Over all line, load, and temperature conditions) | All | $V_{O,set}$ | | 3 | | % $V_{O,set}$ |
| On/Off Logic High (MODULE OFF) Input High Voltage | All | V_{IH} | 2.5 | - | 16 | V_{dc} |
| On/Off Logic Low (MODULE ON) Input Low Voltage | All | V_{IL} | -0.2 | - | 0.6 | V_{dc} |
| PGOOD (Power Good) | | | | | | |
| Signal Interface Open Drain, $V_{supply} \leq 5V_{DC}$ | | | | | | |
| Overshoot threshold for PGOOD ON | All | | | 107.6 | | % $V_{O,set}$ |
| Overshoot threshold for PGOOD OFF | All | | | 112.8 | | % $V_{O,set}$ |
| Undervoltage threshold for PGOOD ON | All | | | 92.2 | | % $V_{O,set}$ |
| Undervoltage threshold for PGOOD Off | All | | | 87.9 | | % $V_{O,set}$ |
| Pulldown resistance of PGOOD pin | All | | | 94 | | Ω |
| Sink current capability into PGOOD pin | All | | 6 | | | mA |

*Additional External Capacitance possible using Tunable Loop

Characteristic Curves

The following figures provide typical characteristics for the IND065BLV Hornet at 25°C.

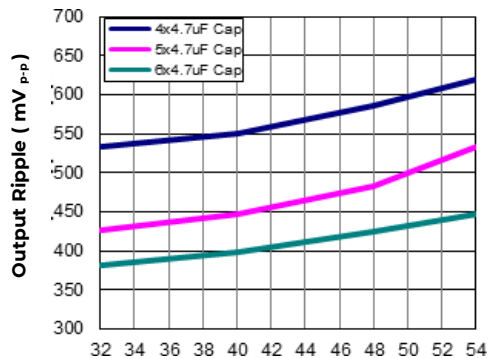

Figure 1. Output Ripple Voltage for various output voltages and external caps @12Vin. Additional Decoupling cap of 0.01uF used on input and output side

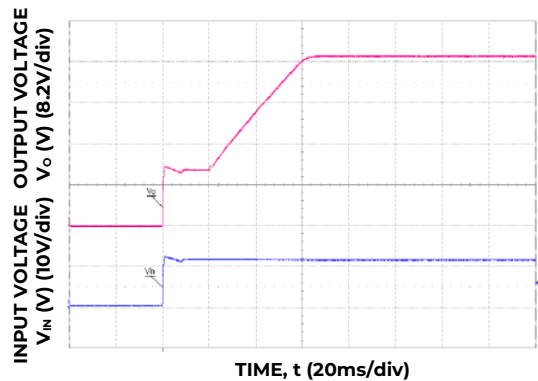

Figure 2. Typical Start-up using Input Voltage ($V_{in}=12V$, $V_{out} = V_{out, max}$, $I_{out} = I_{out, max}$)

Use Current (A) = 65 / Output Voltage (V) to determine baseline output current for a specific voltage. Then thermal curves. Interpolate data for intermediate output voltages

Technical Specification (continued)

Trim

R_{trim} for a desired output voltage, should be as per the following table. The formula in the last column helps determine R_{trim} for other voltages.

| | | | | | | | | |
|--------------------------|--------|--------|--------|--------|--------|-------|-------|--|
| V_o (V) | 16 | 18 | 20 | 22 | 24 | 28 | 34 | $R_{trim} = \left[\frac{12}{(V_o - 1.2)} \right] \times 200.5k\Omega$ |
| R_{trim} (k Ω) | 16.257 | 14.321 | 12.798 | 11.567 | 10.553 | 8.978 | 7.335 | |

Safety Considerations

For safety agency approval, the power module must be installed in compliance with the spacing and separation requirements of the end-use safety agency standards listed on the first page of this document. For the converter output to be considered meeting the requirements of safety extra-low voltage (SELV) or ESI, the input must meet SELV/ESI requirements. The power module has extra-low voltage (ELV) outputs when all inputs are ELV. The input to these units is to be provided with a 12A in the positive input lead.

Tunable Loop

The module is designed for 200uF capacitor on its output. For applications where more than 100uF capacitors would be used on the output, an additional Resistor (R_{tune}) and Capacitor (C_{tune}) would be required in the circuit schematic to compensate for the additional capacitance. The placement is between the Sense+ pin and Trim pin as per figure below:

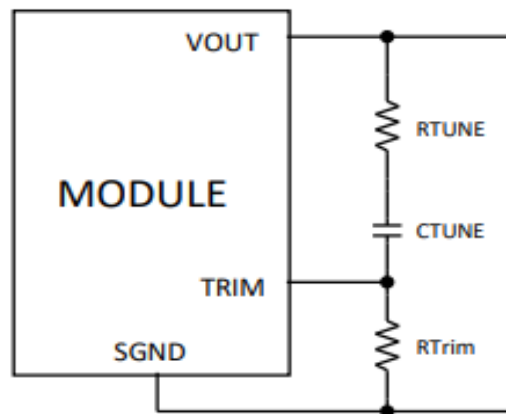

Figure 3. Circuit diagram showing connection of R_{TUNE} and C_{TUNE} to tune the control loop of the module

The recommended values for R_{tune} and C_{tune} for different amounts of external capacitance are as per the table below:

| C_o | 10x10 μ F | 15x10 μ F | 20x10 μ F | 25x10 μ F | 30x10 μ F |
|------------|---------------|---------------|---------------|---------------|---------------|
| R_{TUNE} | 27k Ω | 24k Ω | 20k Ω | 15k Ω | 15k Ω |
| C_{TUNE} | 680pF | 1500pF | 2700pF | 3300pF | 6800pF |

PowerGood (PGOOD)

This is an open-drain output to indicate that the output voltage is within the regulation limits of the module. The PGOOD signal will be de-asserted to a low state if any condition such as overtemperature, overcurrent or loss of regulation occurs that would result in the output voltage going $\pm 10\%$ outside the setpoint value. If not used, leave unconnected.

Technical Specification (continued)

Recommended Pad Layout

Dimensions are in millimeters and (inches).

Tolerances: x.x mm \pm 0.5 mm (x.xx in. \pm 0.02 in.) [unless otherwise indicated]

x.xx mm \pm 0.25 mm (x.xxx in. \pm 0.010 in.)

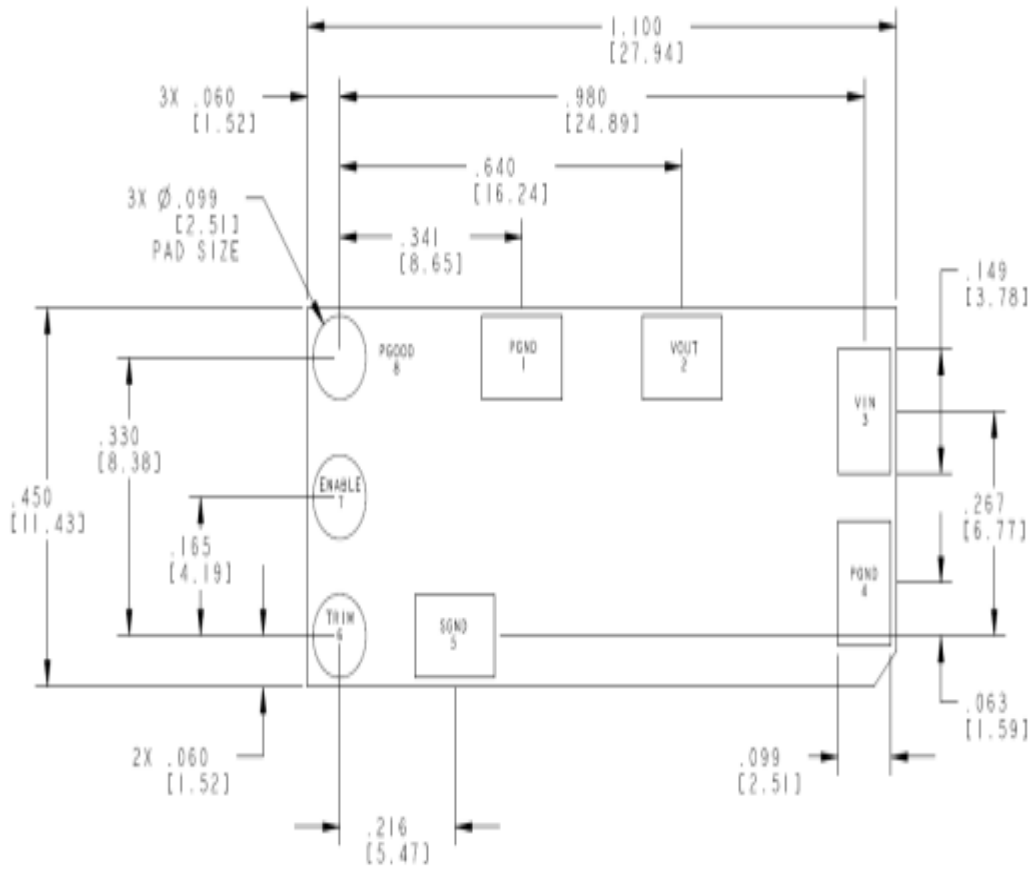

Technical Specification (continued)

Nozzle Recommendations

Stencil thickness of 6 mils minimum must be used for this product. The module weight has been kept to a minimum by using open frame construction. Variables such as nozzle size, tip style, vacuum pressure and placement speed should be considered to optimize this process. The minimum recommended inside nozzle diameter for reliable operation is 3mm. The maximum nozzle outer diameter, which will safely fit within the allowable component spacing, is 7 mm.

Bottom Side / First Side Assembly

This module is not recommended for assembly on the bottom side of a customer board. If such an assembly is attempted, components may fall off the module during the second reflow process

Lead Free Soldering

The modules are lead-free (Pb-free) and RoHS compliant and fully compatible in a Pb-free soldering process. Failure to observe the instructions below may result in the failure of or cause damage to the modules and can adversely affect long-term reliability

MSL Rating

The modules have a MSL rating of 2a.

Pb-free Reflow Profile

Power Systems will comply with J-STD-020 Rev. D (Moisture/Reflow Sensitivity Classification for Nonhermetic Solid State Surface Mount Devices) for both Pb-free solder profiles and MSL classification procedures. The suggested Pb-free solder paste is Sn/Ag/Cu (SAC).

The following profile is the recommended linear reflow profile using Sn/Ag/Cu solder. Soldering outside of the recommended profile requires testing to verify results and performance.

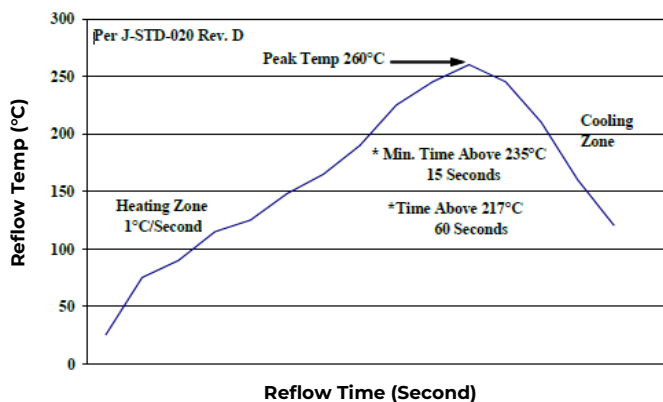

Storage and Handling

J-STD-033 Rev. A (Handling, Packing, Shipping and Use of Moisture/Reflow Sensitive Surface Mount Devices) is recommended. Moisture barrier bags (MBB) with desiccant are required for MSL ratings of 2 or greater. These sealed packages should not be broken until time of use. Once the original package is broken, the floor life of the product at conditions of $\leq 30^{\circ}\text{C}$ and 60% relative humidity varies according to the MSL rating (see J-STD-033A). The shelf life for dry packed SMT packages will be a minimum of 12 months from the bag seal date, when stored at the following conditions: $< 40^{\circ}\text{C}$, $< 90\%$ relative humidity.

Post Solder Cleaning and Drying Considerations

Post solder cleaning is usually the final circuit-board assembly process prior to electrical board testing. The result of inadequate cleaning and drying can affect both the reliability of a power module and the testability of the finished circuit-board assembly

Contact Us

For more information, call us at
 1-877-546-3243 (US)
 1-972-244-9288 (Int'l)

Change History (excludes grammar & clarifications)

| Revision | Date | Description of the change |
|----------|------------|--|
| 4.3 | 10/11/2021 | Updated as per template |
| 4.4 | 05/30/2023 | Correction in electrical specification table on page – 3 |
| 4.5 | 10/18/2023 | Updated as per OmniOn template |

OmniOn Power Inc.

601 Shiloh Rd.
Plano, TX USA

omnionpower.com

We reserve the right to make technical changes or modify the contents of this document without prior notice. OmniOn Power does not accept any responsibility for errors or lack of information in this document and makes no warranty with respect to and assumes no liability as a result of any use of information in this document.

We reserve all rights in this document and in the subject matter and illustrations contained therein. Any reproduction, disclosure to third parties or utilization of its contents – in whole or in parts – is forbidden without prior written consent of OmniOn Power. This document does not convey license to any patent or any intellectual property right. Copyright© 2023 OmniOn Power Inc. All rights reserved.