

## PRODUCT MANUAL

# CPS2500D +/-190V Downstream System

**Notice:** The information, specifications, and procedures in this manual are subject to change without notice. OmniOn Power assumes no responsibility for any errors that may appear in this document

Product Manual  
Select Code 167-102-106  
Ordering Code 848755265  
Issue 4  
January 2008

This page intentionally left blank

**PRODUCT MANUAL**

**CPS2500D +/-190V Downstream System**

**Table Of Contents**

**1.Introduction .....9**

CPS2500D Downstream System.....9

    Overview.....9

    Applications.....9

    Web Site.....9

Customer Service Contacts.....10

    Customer Service, Technical Support.....10

        Product Repair and Return, and Warranty Service .....10

    Customer Training .....10

    On-Line Power Systems Product Manuals.....10

    EasyView software .....10

**2.Product Description**

    Physical Description .....11

    Block Diagram.....11

    Operation .....11

    Specifications .....12

        Electrical .....13

        Maximum Output Power.....14

        Installation category:.....14

**3.Engineering and Ordering**

    Ordering Information.....15

    Engineering.....15

**4.Safety**

    Safety Statements.....17

    Warning Statements and Safety Symbols.....19

        Deutsch.....20

        Espanol.....20

**5.Installation**

    CPS2500D Installation.....21

        Purpose.....21

        Precautions .....21

        Safety.....21

        Installation Tools.....21

    Unpack the CPS2500D Shelf .....21

        CPS2500D Unpack.....20

    Ground Configuration.....22

        Ground Jumper .....22

    Inspect the Network.....22

        Check and Mark Wiring Compliance .....22

## Table Of Contents (Continued)

Install the CPS2500D Shelf.....	23
CPS2500D Frame Install.....	23
CPS2500 Cable Install.....	24
Installing the Converters.....	24
QS882A Converter Installation.....	24
Install the QS882A Converters.....	25
Recognizing Normal States.....	25
Recognize Normal States.....	25
Diagnosing Abnormal States.....	26
Diagnosing Abnormal States.....	26
<b>6. Electrical Interface Reference Information</b>	
Shelf Electrical Interfaces.....	31
Connector Details.....	31
Connector Pinouts.....	31
<b>7. Reference Information</b>	
CPS2500D Shelf.....	33
QS882A Converter.....	34
<b>8. Product Warranty</b>	
<b>Appendix A Operating Temperature and Vertical Spacing</b>	
Overview.....	38
Operating Temperature.....	38
<b>9. Revision .....</b>	<b>39</b>

## List of Figures

Figure 1-1: CPS2500D Downstream System .....	9
Figure 2-1: QS800A Shelf Block Diagram.....	11
Figure 2-2: Unit Maximum Output Power vs. Input Voltage .....	14
Figure 3-1: Constant Delivered Power Curves (normal range of operation).....	15
Figure 5-1: Ground Jumper .....	22
Figure 5-2: QS800A Frame Mounting .....	23
Figure 5-3: ESD Ground Jack .....	24
Figure 5-4: QS800A with All Cables Attached .....	24
Figure 5-5: Align the QS882A Converter .....	25
Figure 5-6: QS800A with All Cables Attached.....	25
Figure 5-7: Recognizing Normal States (with associated LED display definitions).....	25
Figure 5-8: Output Voltage Low - Additional Circuits Required .....	26
Figure 5-9: Converter Internal Fault.....	27
Figure 5-10: Remove Converter.....	27
Figure 5-11: Network Wiring Fault.....	28
Figure 5-12: Network Wiring Faulty on Circuit 6B .....	28
Figure 5-13: Relay Identification for Replacement .....	29
Figure 7-1: QS800A Shelf Mounting Hole Dimensions .....	33
Figure 7-2: Depth and Height Dimensions .....	33
Figure 7-3: 12-Inch Shelf Mounting Hole Dimensions (CC109139853) .....	33
Figure 7-4: Shelf Equipped with 19-Inch Adapter Bracket (CC848828525).....	33
Figure 7-5: Q882A Size .....	34

This page intentionally left blank

## Table of Tables

<b>Table 2-A: Absolute Maximum Ratings .....</b>	<b>12</b>
<b>Table 2-B: Electrical Specifications .....</b>	<b>13</b>
<b>Table 7-A: LED Truth Table .....</b>	<b>35</b>

This page intentionally left blank



## 1 Introduction

### CPS2500D Downstream System

#### Overview

The CPS 2500D System consists of up to ten QS882A dual converter cards in a shelf with input and output wiring and an alarm and connector card on the right side. Each converter on the QS882A card:

- Accepts 100VA limited source voltage in a range of 190 to 395 volts.
- Delivers up to 65W at nominal -48 volts.

A fully configured shelf delivers a maximum load power of 1300 Watts in an outdoor cabinet. If converter card redundancy is desired the maximum power that can be delivered is 1170 Watts.

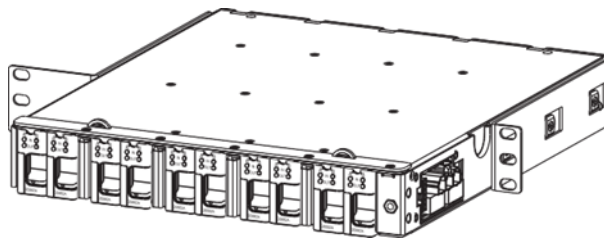

Figure 1-1: CPS2500D Downstream System

#### Application

The CPS2500D is the part of a telephone line powered system that is located with the video switching equipment at a site not served by batteries - typically a cross connect cabinet. It is designed to operate most optimally from a CPS3200U source on the other end of the telephone lines near a battery reserve, but works with other upstream vendor equipment.

#### Web Site

For further information about CPS6000 systems visit the CPS6000 Web site at [omnionpower.com](http://omnionpower.com)

## Customer Service Contacts

### **Customer Service, Technical Support, Product Repair and Return, and Warranty Service**

For customers in the United States, Canada, Puerto Rico, and the US Virgin Islands, call 1-877-546-3243 This number is staffed from 7:00 am to 5:00 pm Central Time (zone 6), Monday through Friday, on normal business days. At other times this number is still available, but for emergencies only. Services provided through this contact include initiating the spare parts procurement process, ordering documents, product warranty administration, and providing other product and service information.

For other customers worldwide the 800 number may be accessed after first dialing the OmniOn Direct country code for the country where the call is originating, or you may contact your local field support center or your sales representative to discuss your specific needs.

### **Customer Training**

OmniOn Power offers customer training on many Power Systems products.

For information call 1-972-244-9288. This number is answered from 8:00 a.m. until 4:30 p.m., Central Time Zone (Zone 6), Monday through Friday.

### **Downloads and Software**

To download the latest product information, product software and software upgrades, visit our web site at [omnionpower.com](http://omnionpower.com)

## 2 Product Description

### Physical Description

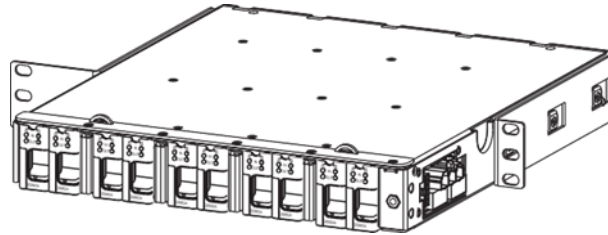

### Block Diagram

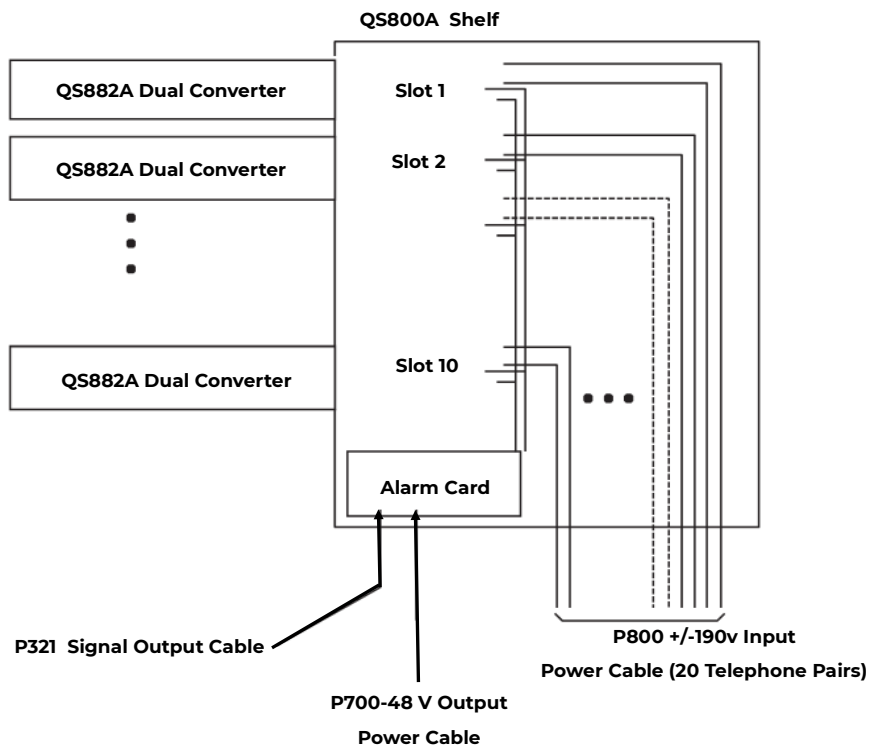

Figure 2-1: QS800A Shelf Block Diagram

### Operation

Power comes in on P800 from up to 20 independent 100VA +/- 190V circuits. Power comes out on P700 at -54 volts. Maximum current for a fully provisioned shelf is 24 Amps or 1300 Watts. Major and minor alarms are available on P321. The alarms are configured as Form C closures. A major indicates circuit or input failure on 2 or more circuits. A minor alarm indicates circuit or input failure of one circuit.

Section 5 has a step by step installation and trouble shooting process using the Display LEDs as a primary guide to next actions.

## Specifications

Parameter	Symbol	Min	Typ	Max	Unit
<b>Input Voltage</b>					
Continuous	V <sub>I</sub>	0	380	400	V <sub>dc</sub>
Transient Duration = 10ms	V <sub>tr</sub>	400		TBD	V <sub>dc</sub>
<b>Temperature</b>					
Normal Operating Ambient Temperature at 150 lfm airflow	T <sub>A</sub>	-40		65	°C
Operating Ambient Temperature at higher (TBD) airflow (See Thermal Considerations section)	T <sub>A</sub>	-40		75	°C
Storage Temperature	T <sub>stg</sub>	-55		125	°C
<b>Power</b>					
Input Power (per Power unit)	P <sub>in</sub>			200	W
Power Dissipation (Power unit Dissipation)	P <sub>diss</sub>		27	TBD	W
Output Power (per Power unit)	P <sub>out</sub>		130	TBD	W
<b>Isolation</b>					
Input to Output Voltage				1500	V <sub>dc</sub>

**Table 2-A: Absolute Maximum Ratings**

## Electrical

Unless otherwise specified, specifications apply over all operating input voltage, output load current and temperature conditions.

Parameter	Symbol	Min	Typ	Max	Unit
<b>Input</b>					
Operating Input Voltage	$V_i$	130	391.1	400	$V_{dc}$
Maximum Input Current ( $\pm 190 V_{dc}$ : $V_{ioc}=320 V_{dc}$ to $398 V_{dc}$ , $I_o=I_o, max$ )		0.233	0.241	0.250	
Future Code: ( $\pm 130 V_{dc}$ : $V_{ioc}=250 V_{dc}$ to $278 V_{dc}$ , $I_o=I_o, max$ )	$I_{in max}$				$A_{dc}$
Inrush Transient (Duration: $\leq 1.0$ ms)	$I_{pk}$			0.25	$A_{dc}$
<b>Output (per Power Unit, 2 Circuits)</b>					
Output Voltage Set-point ( $V_{in}=V_{in min}$ , $I_o=1.47A$ , $T_a=25^\circ C$ )	$V_{o, set}$		-54.5		$V_{dc}$
Output Voltage (Over all operating input voltage, resistive load, an temperature conditions until end of life)	$V_o$	-52.0	--	-55.0	$V_{dc}$
Output Regulation Line ( $V_{in}=V_{in min}$ to $V_{in max}$ )		--	0.5	--	$\%V_o$
Load* ( $I_o=I_o min$ to $I_o max$ )		--	TBD	3.5	$\%V_o$
*Output voltage droops as load current increases to provide system current sharing. Temperature ( $T_a = -40^\circ C$ to $+85^\circ C$ )		--	150	--	mV
Output Ripple and Noise on nominal output ( $V_{in}=V_{in nom}$ and $I_o=I_o min$ to $I_o max$ )					
RMS (5Hz to 20MHz bandwidth)		--	140	--	mVrms
Peak-to-Peak (5Hz to 20MHz bandwidth)		--	200	--	mVpk
External Capacitance	$C_o max$	--	--	3,000	$\mu F$
Output Power (per circuit pair, $V_o=V_o min$ )	$I_o$	0		2.5	$A_{dc}$
Efficiency ( $I_o=I_o max$ , $V_o=V_o set$ , $T_a=25^\circ C$ ) $V_{in}=260V$ $V_{in}=380V$	$\eta$		86 83	%	
Dynamic Load Response ( $D(I_o)/Dt=1A/10\mu s$ , $V_{in}=V_{in nom}$ , $T_a=25^\circ C$ )					
Load Change from $I_o=50\%$ to $75\%$ of $I_o max$	$V_{pk}$				$\%V_o set$
Peak Deviation	$t_s$				$\mu s$
Load Change from $I_o=75\%$ to $50\%$ of $I_o max$	$V_{pk}$				$\%V_o set$
Peak Deviation	$t_s$				$\mu s$
Settling Time ( $V_o < 10\%$ peak deviation)					

Table 2-A: Electrical Specifications

## Maximum Output Power

The following graph shows the low side tolerance output power from the pair of dc/dc circuits on each unit, as input voltage delivered to the unit varies due to losses in the copper feeder pairs. Efficiency is assumed to be linear with 84% at  $V_{in}$  minimum of 190V ( $P_{in} = 2 \times (190 \times 0.239) = 2 \times 45.41W = 90.82W$ ), and 83% at  $V_{in}$  maximum of 380V; maximum input current is limited to 0.239 Amps at all input voltages.

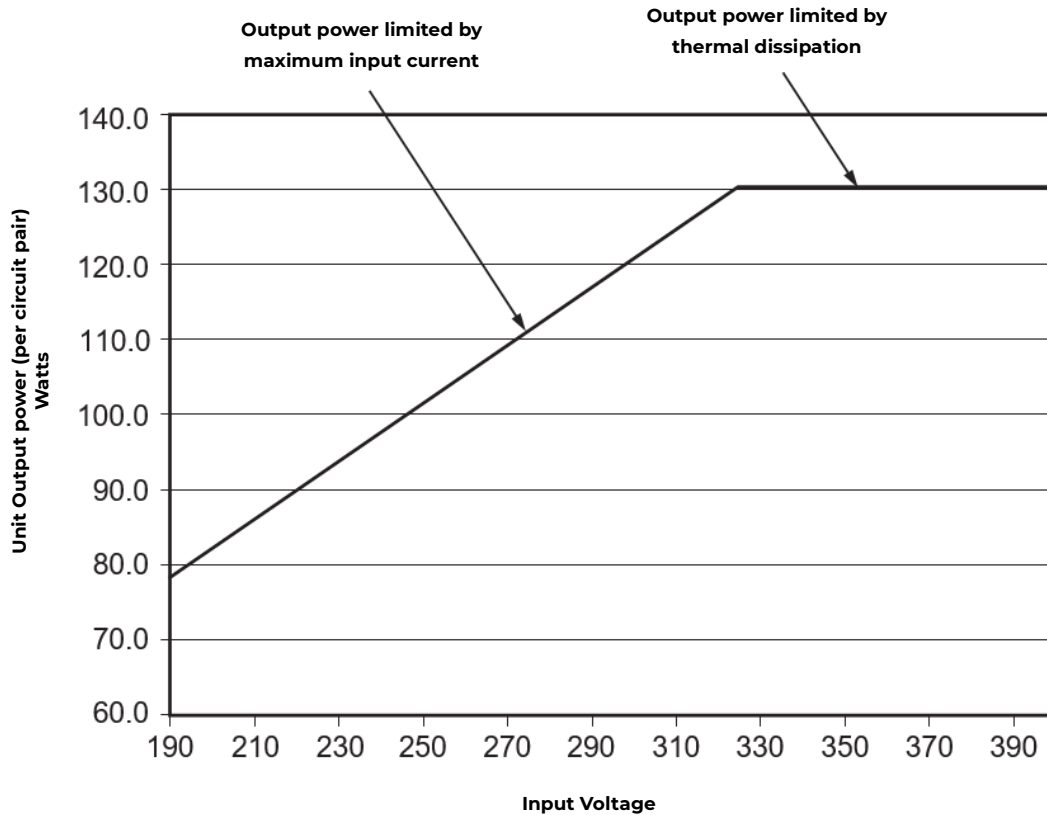

Figure 2-2: Unit Maximum Output Power vs. Input Voltage

Unit Maximum Output Power vs. Input Voltage when fed from +/-190V upstream source.

### Installation category:

Input power shall be provided by up to 20 telephone wire pairs. The host system must protect each pair to a level corresponding to a CommScope 3C\*EW Gas tube primary protector. This protector has a voltage breakdown range of 265-465 Volts and an impulse spark over range of <265-700 Volts.

### 3 Engineering and Ordering

#### Ordering Information

Shelf	Description	Ordering Code
QS882A	Converter Unit	108994918
QS800A	Shelf	108994926
QS800B	12-Inch Complete Shelf (requires external ground connection)	CC109139853
	19-Inch Adapter Bracket	CC848828525

#### Engineering

Engineering a telephone line powered system requires knowledge about the resistance of the input wires feeding each circuit. To make a rough estimate follow these steps. An example follows each step in [ ] brackets.

1. Assess the total resistance of the loop feeding each circuit. [ 600Ω ]
2. Decide how much power your load requires. [ 600W ]
3. Choose the highest power curve available for circuits with the input resistance provided by your network. [ For 600Ω, the 60Watt line almost works. This looks like about 58 Watts.]
4. Use the 80% efficiency factor to determine how much power is delivered per circuit. [58 Watts \* .8 = 46.4 Watts]
5. Divide your total load by the power delivered per circuit to determine the minimum number of circuits required to support the load. [ 600 Watts / 46.4 Watts = 12. 93 circuits or 13 circuits.]
6. Add cards to reach the level of redundancy desired. [ One card redundancy so 16 circuits or 8 cards.]

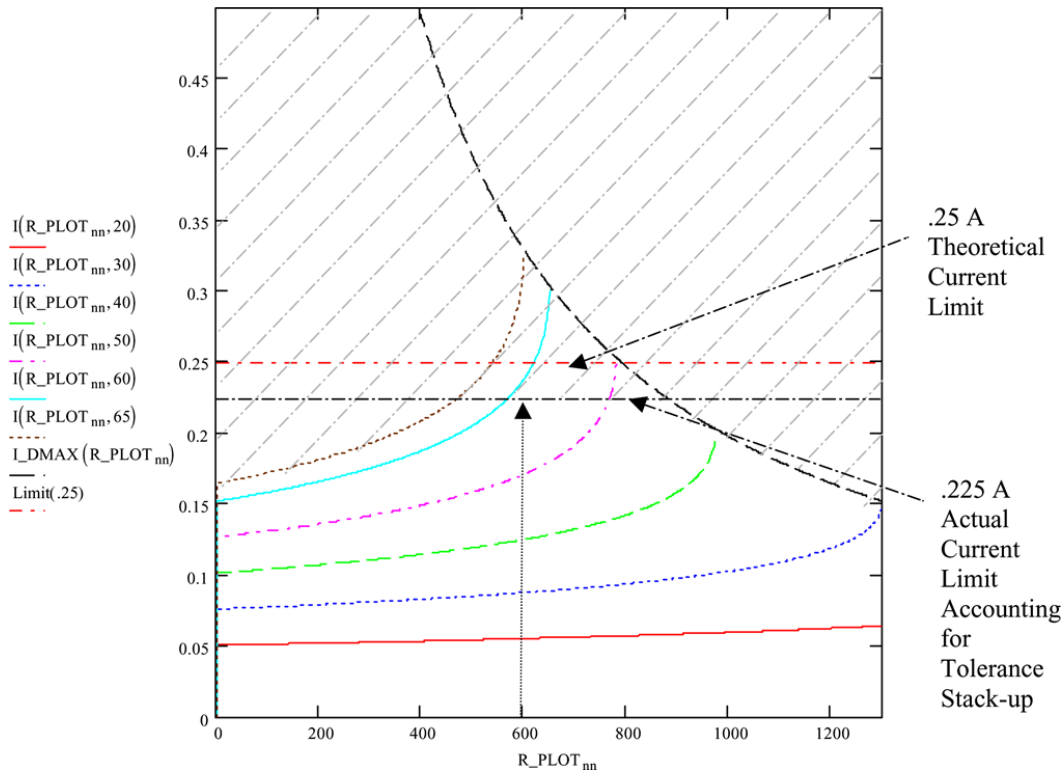

Figure 3-1: Constant Delivered Power Curves (normal range of operation)

This page intentionally left blank



## 4 Safety

### Safety Statements

Please read and follow all safety instructions and warnings before installing, maintaining, or repairing the system:

- The system is Underwriters Laboratories (UL) Recognized per the applicable requirements of UL60950-1 and UL60950-21.
- For the product to be safe the chassis must be grounded by a permanent means.
- The return conductor of the -48V shall be earthed.
- Install only in restricted access areas (dedicated equipment rooms, equipment closets, or the like) in accordance with articles 110-31, 110-32, and 110-33 of the U.S. National Electric Code (NEC), ANSI/NFPA No. 70, and pursuant to applicable local codes.
- The telecommunication line cable, carrying the +/-190V, shall be minimum 26 AWG, and rated minimum 200V. Consideration shall be taken at the time of installation to verify cable rating.
- Primary protection must be provided on all the telecommunication line cable consistent with UL 497.
- Airflow must be provided at a rate of 150 lfm across the entire cross section of the shelf for operation in environments from -40°C to 65°C.
- This equipment is to be used in controlled environments (an area where the humidity is maintained at levels that cannot cause condensation on the equipment, the contaminating dust is controlled, and the steady-state ambient temperature is within the range specified).
- This equipment must not be installed over combustible surfaces.
- For installations in the United States, Listed compression connectors are to be used to terminate Listed field-wired conductors where required. For all installations, the appropriate connector is to be applied only to the correct size conductor as specified by the connector manufacturer, using only the connector manufacturer's recommended tooling or tooling approved for that connector.
- If the proper connector for the country of installation is not provided, obtain appropriate connectors and follow manufacturer's and all local requirements for proper connections. All national and local rules and regulations should be followed when making field connections.
- A bulk output option is provided; load connections should be made in close proximity to the power shelf.
- The main input voltage (+/-190V) shall meet UL60950-21 RFT-V requirements. DO NOT CONNECT TO RFT-C CIRCUITS.
- The main output voltage (48V) meets SELV requirements.
- Insulation on field-wired conductors should be rated no less than 90° Celsius. Wire conductor size should be sized per electrical codes for 75° Celsius wire, and based on the ampacity of the associated protection device. Wiring internal to enclosed equipment cabinets should be rated at 105° Celsius (minimum).
- Torque electrical connections to the values specified on labels or in the product documentation.
- Cables must be dressed to avoid damage to the conductors (caused by routing around sharp edges or routing in areas where wires could get pinched) and undue stress on the connectors.
- Alarm contacts are not fused in the shelf; therefore, current limiting protection for these contacts must be provided by external circuits. Maximum ratings for alarm connections are 60Vdc and 0.5 amperes. Exceeding these maximum ratings could result in fire or damage to the unit.
- For applications in cabinets, huts, vaults, and central offices, the system mounting framework must be connected to the system integrated ground grid.
- The designed capacitance between +/-190V RFT-V conductors is 1uF and the measured capacitance between +/-190V and earth is 1uF. DO NOT add capacitance to the system to reach values that exceed safety limits per the following figure:

## 4 Safety (Continued)

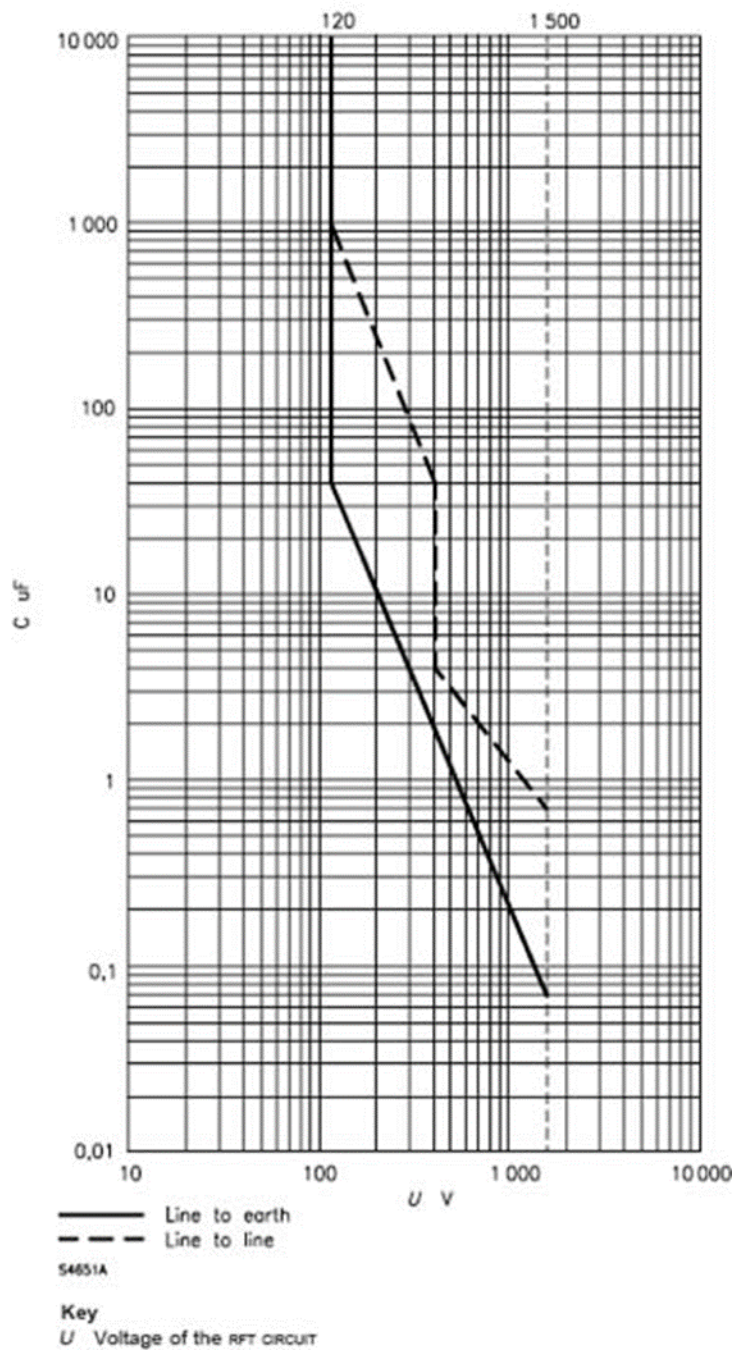

## Warning Statements and Safety Symbols

The symbols may sometimes be accompanied by some type of statement; e.g., “Hazardous voltage/energy inside. Risk of injury. This unit must be accessed only by qualified personnel.” Signal words as described below may also be used to indicate the level of hazard

**DANGER** Indicates the presence of a hazard that will cause death or severe personal injury if the hazard is not avoided.

**WARNING** Indicates the presence of a hazard that can cause death or severe personal injury if the hazard is not avoided.

**CAUTION** Indicates the presence of a hazard that will or can cause minor personal injury or property damage if the hazard is not avoided.



This symbol identifies the need to refer to the equipment instructions for important information.



These symbols (or equivalent) are used to identify the presence of hazardous ac mains voltage.



This symbol is used to identify the presence of hazardous ac or dc voltages. It may also be used to warn of hazardous energy levels.



One of these two symbols (or equivalent) may be used to identify the presence of rectifier and battery voltages. The symbol may sometimes be accompanied by some type of statement, for example: “Battery voltage present. Risk of injury due to high current. Avoid contacting conductors with uninsulated metal objects. Follow safety precautions.”



One of these two symbols may be used to identify the presence of a hot surface. It may also be accompanied by a statement explaining the hazard. A symbol like this with a lightning bolt through the hand also means that the part is or could be at hazardous voltage levels.



This symbol is used to identify the protective safety earth ground for the equipment.



This symbol is used to identify other bonding points within the equipment.



This symbol is used to identify the need for safety glasses and may sometimes be accompanied by some type of statement, for example: “Fuses can cause arcing and sparks. Risk of eye injury. Always wear safety glasses.”

## Precautions

When working on or using this type of equipment, the following precautions should be noted:

- This unit must be installed, serviced, and operated only by skilled and qualified personnel who have the necessary knowledge and practical experience with electrical equipment and who understand the hazards that can arise when working on this type of equipment.
- The equipment could be powered by multiple ac inputs. Ensure that the appropriate circuit protection device for each ac input being serviced is disconnected before servicing the equipment. Do not disconnect permanent bonding provisions unless all ac inputs are disconnected.
- Batteries may be connected in parallel with the output of the rectifiers. Turning off the rectifiers will not necessarily remove power from the bus. Make sure the battery power is also disconnected and/or follow safety procedures while working on any equipment that contains hazardous energy/voltage.
- Hazardous energy and voltages are present in the unit and on the interface cables that can shock or cause serious injury. Follow all safety warnings and practices when servicing this equipment. When equipped with ringer modules, hazardous voltages will be present on the ringer output connectors.
- In addition to proper job training and safety procedures, the following are some basic precautions that should always be used:
  - Use only properly insulated tools.
  - Remove all metallic objects (key chains, glasses, rings, watches, or other jewelry).
  - Wear safety glasses. Fuses can produce sparks. High energy levels on buses and distribution components can produce severe arcing.
  - Test circuits before touching.
  - Lock out and tag circuit breakers/fuses when possible to prevent accidental turn on.
  - Be aware of potential hazards before servicing equipment.
  - Identify exposed hazardous electrical potentials on connectors, wiring, etc. (note the condition of these circuits, especially wiring).
  - Use care when removing or replacing covers; avoid contacting circuits.

## Special Installation Notes

**Deutsch**      Installationsanleitung

**Espanol**      Notas especiales para instalaciones en países de habla hispana

## 5 Installation

### CPS2500D Installation

#### Purpose

CPS 2500D Shelf Installation

#### Precautions

Observe ESD protection while installing circuit packs

#### Safety

- Always consider personal safety.
- Make sure the system is properly grounded per the National Electrical Code and local building codes.
- Remove all metal jewelry before beginning the installation.

#### Installation Tools

- Wire cutters and strippers
- Heat shrink gun
- Torque wrench (0-240 inch-lb or 28 Nm)
- 5/16 inch (8mm) hex driver
- 10 mm hex driver
- 48 Volt test load
- Digital meter with an accuracy of +/- 0.02%
- Screw Drivers (flat-blade and Phillips)
- ESD wrist strap

### Unpack the CPS2500D Shelf

#### CPS2500D Unpack

The box contains:

- One QS800A Shelf
- One 848744961 Power Cable
- One 848745547 Alarm Signal Cable
- Product documentation

Step	Action
1	Unpack the box. Inspect the shipping container for any signs of damage. If damage exists, have the carrier's representative sign a note acknowledging the damage.
2	Carefully cut the sealing tape and remove the shelf, cables and documentation from the carton.
3	Save the shipping package until all parts are operating within specifications.

## Ground Configuration

### Ground Jumper

Step	Action	Action
1	Is Ground to RTN connection made on a fuse or distribution panel?	
	Yes - If Ground Jumper is present, remove Ground Jumper as shown below.	No - If Ground Jumper is not present, install Ground Jumper as shown below.

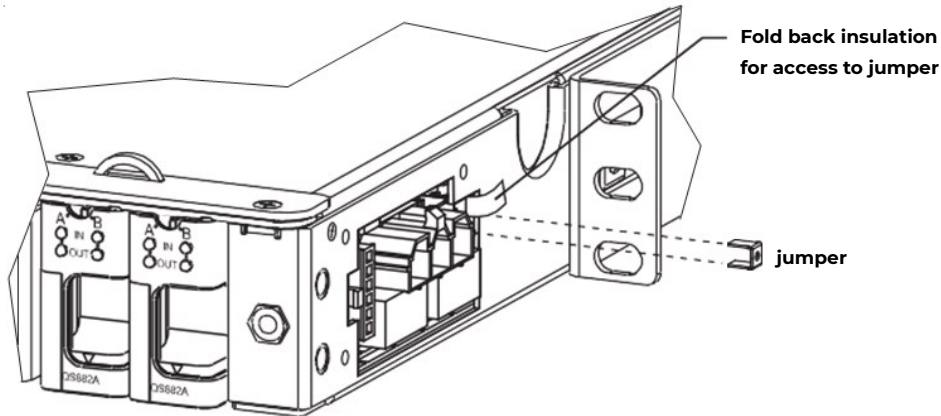

Figure 5-1: Ground Jumper

## Inspect the Network

### Check and Mark Wiring Compliance

Each location in the network where the input is available to be touched must be protected and marked as an A2 voltage.

Step	Action			
1	Is accessibility to the circuit throughout the network consistent with A2 requirements?			
	Voltage Class	General Public	Employees	Craftsperson
	A1	Restricted Access	Exposed	Exposed
	A2	Inaccessible	Restricted Access	Exposed
	A3	Inaccessible		Restricted Access (Exceptions)
2	Is the 5-pin protector marked as a special circuit?			
3	Does the 5-pin protector protect each pair to a level corresponding to a CommScope 3C*EW Gas tube primary protector? This protector has a voltage breakdown range of 265-465 Volts and an impulse spark over range of <265-700 Volts. Protectors with a lower voltage breakdown rating will be problematic.			

To meet UL60950-21 specific procedural steps must be taken at the time of installation. This section goes through those steps. These steps should be performed before power is distributed in the network. Normally the final step is performed by closing the circuit using a 5-pin protector after DC power is applied to the system.

## Check and Mark Wiring Compliance (Continued)

Step	Action
1	Recognize that the Remote Feed Telecommunication Voltage limited (RFT-V) circuit is voltage limited to +190V and -190V from ground.
2	Is the total capacitance to ground on each line of the circuit less than 10 $\mu$ F? The QS882A introduces less than 1 $\mu$ F. The sourcing electronics and line must introduce less than 9 $\mu$ F of capacitance.
3	Is the total capacitance line to line of the circuit less than 40 $\mu$ F? The QS882A introduces less than 1 $\mu$ F. The sourcing electronics and line must introduce less than 39 $\mu$ F of capacitance from tip to ring.
4	Is the remote equipment also a RFT-V voltage limited circuit? Both ends of the circuit must be designed to the same standard. This must be verified before the equipment is connected together.
5	Is the voltage rating of the Network Wiring sufficient to support 190V to ground?
6	Is the chassis of the system bonded to ground? Verify by both observation and measurement before powering the system.

## Install the CPS2500D Shelf

### CPS2500D Frame Install

Use the following procedure to mount the CPS 2500D shelf into a frame with mounting holes located on 12.9 inch (328 mm) centers.

Step	Action		
1	Locate the 2 mounting brackets, one on each side of the QS800A shelf; align the holes in the shelf-mounting bracket with the holes in the mounting frame. See Figure 5-2.		
2	Attach the CPS shelf to the frame using 6 screws threaded to match the holes in the equipment frame. Refer to the table below for Torque Specifications.		
	<b>Torque</b>		
	<b>Hardware</b>	<b>Nm</b>	<b>In-lb</b>
	Metric M5	4	35
	12-24	4	35
	Metric M6	7.3	65

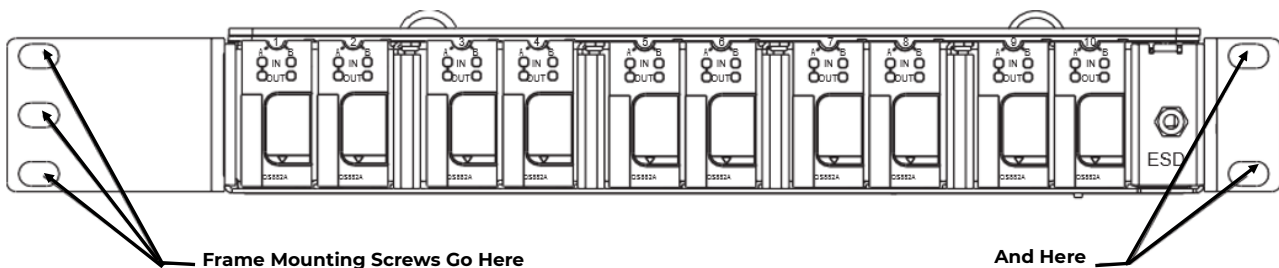

Figure 5-2: QS800A Frame Mounting

## Install the CPS2500D Shelf (continued)

### CPS2500 Cable Install

Follow the steps below to route cables to and from the QS800A shelf.

Step	Action
1	Insert ESD wrist strap pin into ESD jack shown in Figure 5-3.
2	Connect the ground lug to the shelf as shown in Figure 5-3. Use two 10-32 by 5/8 inch or shorter threaded fasteners and a double hole lug with holes on 5/8 inch centers to secure a 6 AWG ground lead to the location on the right of the shelf just in front of the power output connectors. Torque to 30 inch -lbs.
3	Locate the 2 included cable sets that came with the shelf and the pigtailed 50 pin connector that is permanently attached to the shelf.
4	Attach the 2 included cable sets, 848744961 and 848745547, to the QS800A Shelf as shown in Figure 5-4. The connectors are keyed so that they only fit in the correct way.
5	Attach the terminal ends of each cable, labeled P800 for input +/- 190V, P700 for -48V out, and P321 for signals out, to the using equipment according the Figure 5-4 and documentation for the using equipment.

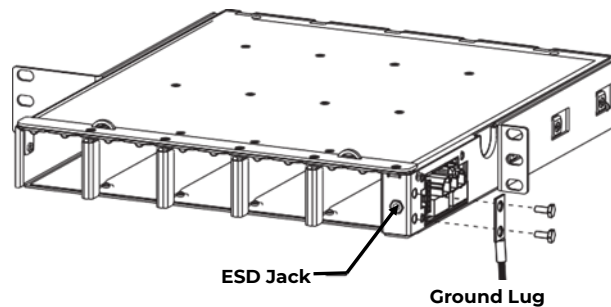

Figure 5-3: ESD Ground Jack

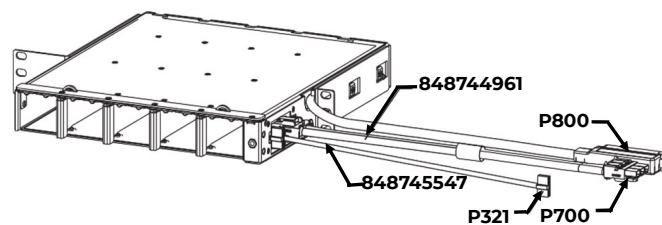

Figure 5-4: QS800A with All Cables Attached

## Installing the Converters

### QS882A Converter Installation

QS882A Converters mount in the QS800 shelf. Note that numbering starts from the left and is correlated to the marking on the 5-pin protector block cabinet input wiring panels.

**Warning:** You must properly protect yourself against ESD discharge prior to installing the QS882A Controller.

**Note:** There is an ESD cord connection located on the right side of the shelf.



## Install the QS882A Converters

This procedure is used to install each QS882A Converter.

Step	Action
1	Remove the QS882A converter from its shipping container.
2	Align the plastic converter housing on the right and insulated circuit board on the left.
3	Guide the converter into the first available slot by positioning the plastic converter housing in the notch on the top right edge of the opening. See Figure 5-5.
4	Slide the converter into the shelf until it is fully seated in the connector on the rear of the CPS shelf.
5	Push the display faceplate into the shelf until the latch on the top of the converter housing catches. See Figure 5-6.
6	Repeat this process as needed for your application.

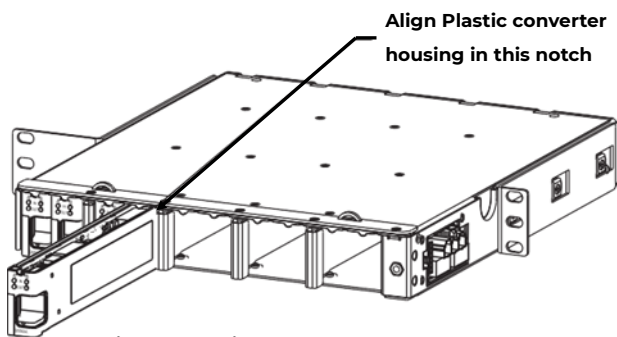

Figure 5-5: Align the QS882A Converter

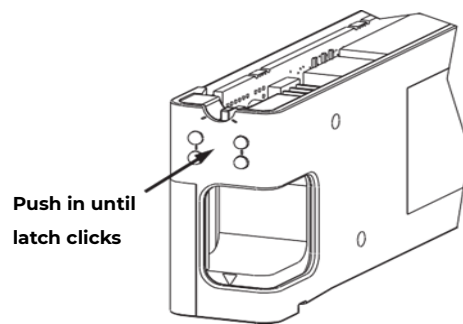

Figure 5-6: QS800A with All Cables Attached

## Recognizing Normal States

### Recognize Normal States

Once power is provided to the CPS 2500D system the LEDs on the converters will illuminate. Understanding what the LEDs mean allows one to recognize normal states and diagnose abnormal states. The top row of LEDs show the state of the input to the converters. The bottom row of LEDs show the state of the output from the converters.

Step	Action	
1	Observe the LEDs.	
2	Does the display look like a combination of the states shown in Figure 5-7: Normal States?	
3	Yes - The system is operating normally. Proceed to the next task.	No - Continue to Diagnosing Abnormal States.

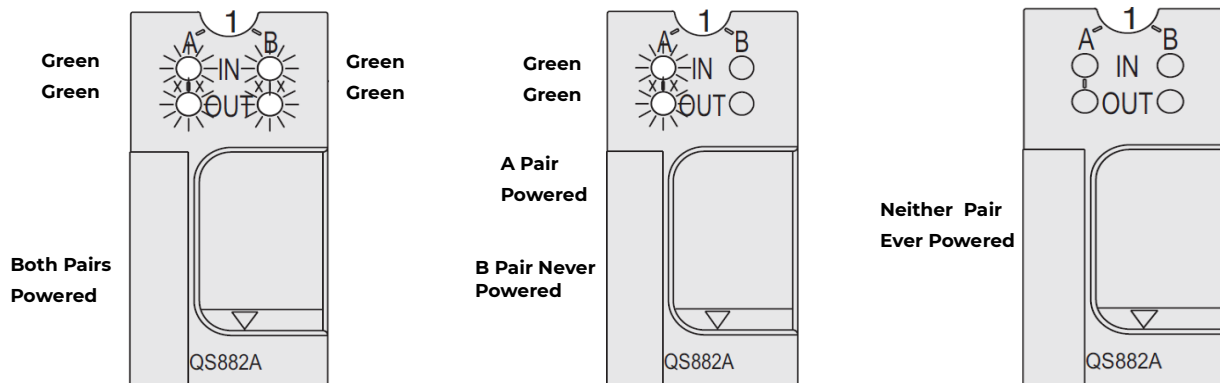

Figure 5-7: Recognizing Normal States (with associated LED display definitions)

## Diagnosing Abnormal States

### Diagnosing Abnormal States

Abnormal states are presented in order of increasing difficulty to repair:

- a) Output Voltage Low-Additional Circuits Required
- b) One converter fault or two converter faults
- c) Network Wiring Fault

Step	Action	
1	Observe the LEDs.	
2	Does the display look like a combination of the states shown in Figure 5-8: Normal States?	
3	Yes - The system load exceeds the sourcing capability of the CPS2500D shelf. Add additional converters following the procedure described as QS882A Converter Installation.	No - Continue to the next step Diagnosing Abnormal States.

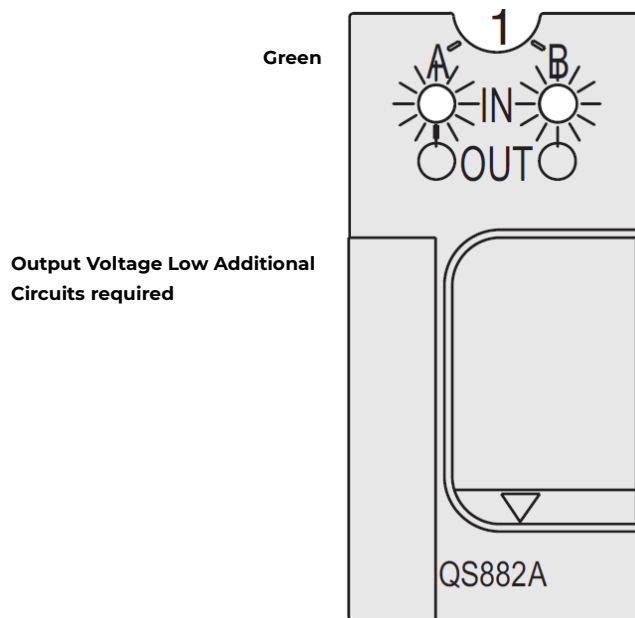

**Figure 5-8: Output Voltage Low - Additional Circuits Required**

## Diagnosing Abnormal States (Continued)

### Diagnosing Abnormal States

**Abnormal state:**

One converter fault and two converter faults.

Step	Action
1	Observe the LEDs.
2	Does the display look like a combination of the states shown in Figure 5-9: Converter Internal Fault?
3	Yes - Replace the faulty converter by first removing it as shown in Figure 5-10 and then installing a replacement converter following the procedure described as QS882A Converter Installation. No - Continue to the next step of Diagnosing Abnormal States.

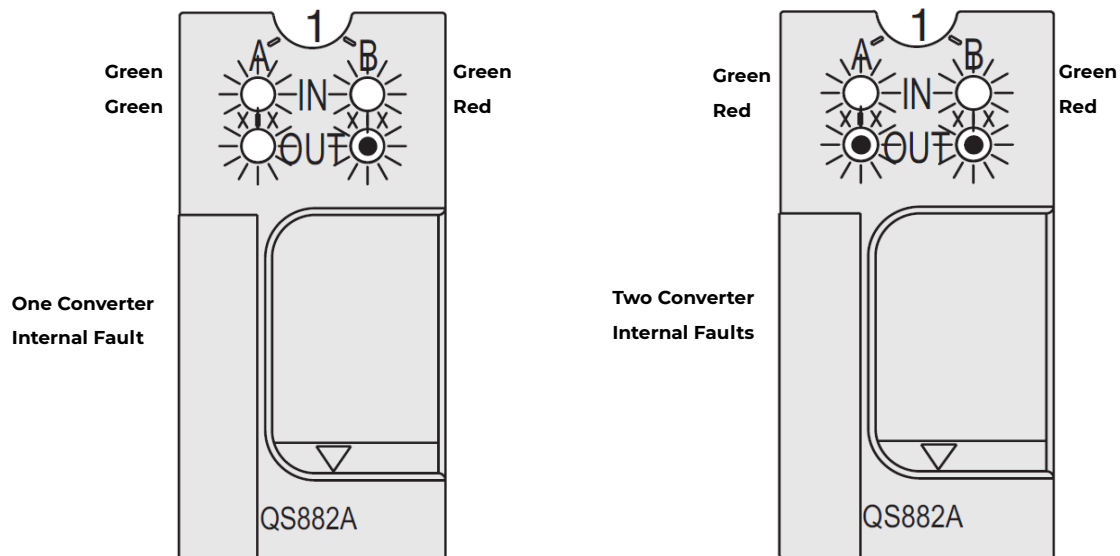

Figure 5-9: Converter Internal Fault

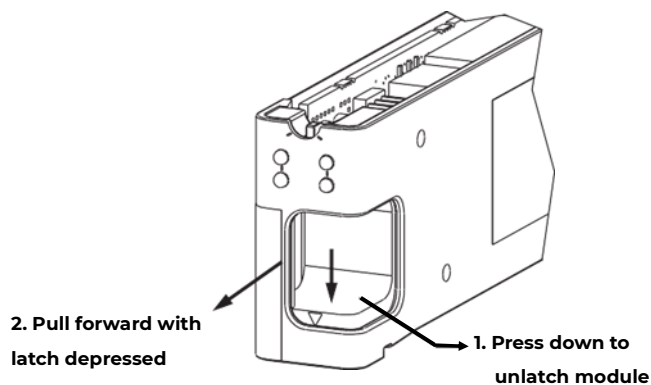

Figure 5-10: Remove Converter

## Diagnosing Abnormal States (Continued)

### Diagnosing Abnormal States

**Abnormal state:**

Network Wiring Fault

Step	Action
1	Observe the LEDs.
2	Does the display look like a combination of the states shown in Figure 5-11: Network Wiring Fault?
3	Yes - Trace the fault back to the 5 pin protector and circuit where it enters the cabinet using the slot identifiers and circuit identifiers as shown in example Figure 5-12: Network Wiring Faulty on Circuit 6B. The problem resides outside the CPS2500D system. Resolve the wiring problem using the standard procedures provided by the network service provider. No - Continue to the next step of Diagnosing Abnormal States.

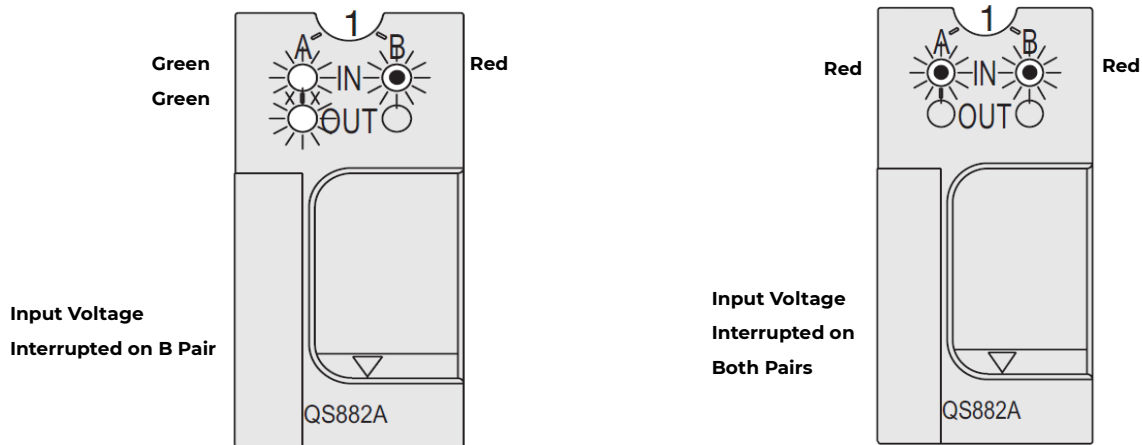

Figure 5-11: Network Wiring Fault

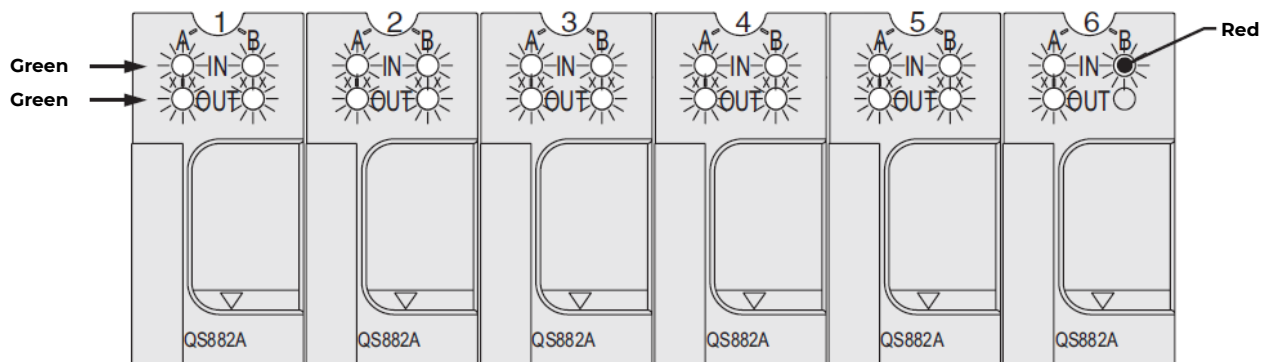

Figure 5-12: Network Wiring Faulty on Circuit 6B

## Diagnosing Abnormal States (Continued)

### Diagnosing Abnormal States

Resolving Abnormal states starting from the office alarms. The CPS2500D provides Power Major and Power Minor office alarms according to this logic: one converter circuit output out of limits is a minor; two converter circuits out of limits is a major.

Step	Action		
1	Observe the office alarm contact closure states. Do you have a Power Major or a Power Minor Alarm?		
2	<table border="0" style="width: 100%;"> <tr> <td style="width: 50%; vertical-align: top;"> <p>For Power Major Alarms,</p> <p>a) Observe the LEDs on the module in position 1.</p> <p>b) Use the Diagnosing Abnormal States using LEDs above to resolve the state of the first QS882A module to a normal state.</p> <p>c) Work across the shelf position by position until all QS882A converters are displaying a normal state.</p> <p>d) If all the modules are displaying a normal state and a Power Major is still being issued the Power Major Relay should be replaced. The power Major Relay is marked K1 and located closer to the back of the shelf in Figure 5-13.</p> <p>e) Replace the Socketed Relay with OmniOn Power Part Number 406789586.</p> <p>f) Confirm that the alarms have been successfully retired</p> </td> <td style="width: 50%; vertical-align: top;"> <p>For Power Minor Alarms,</p> <p>a) Observe the LEDs on the module in position 1.</p> <p>b) Work across the shelf position by position until the QS882A displaying an abnormal state is found.</p> <p>c) Use the Diagnosing Abnormal States using LEDs above to resolve the state of that QS882A module to a normal state.</p> <p>d) If all the modules are displaying a normal state and a Power Minor is still being issued the Power Minor Relay should be replaced. The power Minor Relay is marked K2 and located closer to the front of the shelf in Figure 5-13.</p> <p>e) Replace the Socketed Relay with OmniOn Power Part Number 406789586.</p> <p>f) Confirm that the alarms have been successfully retired</p> </td> </tr> </table>	<p>For Power Major Alarms,</p> <p>a) Observe the LEDs on the module in position 1.</p> <p>b) Use the Diagnosing Abnormal States using LEDs above to resolve the state of the first QS882A module to a normal state.</p> <p>c) Work across the shelf position by position until all QS882A converters are displaying a normal state.</p> <p>d) If all the modules are displaying a normal state and a Power Major is still being issued the Power Major Relay should be replaced. The power Major Relay is marked K1 and located closer to the back of the shelf in Figure 5-13.</p> <p>e) Replace the Socketed Relay with OmniOn Power Part Number 406789586.</p> <p>f) Confirm that the alarms have been successfully retired</p>	<p>For Power Minor Alarms,</p> <p>a) Observe the LEDs on the module in position 1.</p> <p>b) Work across the shelf position by position until the QS882A displaying an abnormal state is found.</p> <p>c) Use the Diagnosing Abnormal States using LEDs above to resolve the state of that QS882A module to a normal state.</p> <p>d) If all the modules are displaying a normal state and a Power Minor is still being issued the Power Minor Relay should be replaced. The power Minor Relay is marked K2 and located closer to the front of the shelf in Figure 5-13.</p> <p>e) Replace the Socketed Relay with OmniOn Power Part Number 406789586.</p> <p>f) Confirm that the alarms have been successfully retired</p>
<p>For Power Major Alarms,</p> <p>a) Observe the LEDs on the module in position 1.</p> <p>b) Use the Diagnosing Abnormal States using LEDs above to resolve the state of the first QS882A module to a normal state.</p> <p>c) Work across the shelf position by position until all QS882A converters are displaying a normal state.</p> <p>d) If all the modules are displaying a normal state and a Power Major is still being issued the Power Major Relay should be replaced. The power Major Relay is marked K1 and located closer to the back of the shelf in Figure 5-13.</p> <p>e) Replace the Socketed Relay with OmniOn Power Part Number 406789586.</p> <p>f) Confirm that the alarms have been successfully retired</p>	<p>For Power Minor Alarms,</p> <p>a) Observe the LEDs on the module in position 1.</p> <p>b) Work across the shelf position by position until the QS882A displaying an abnormal state is found.</p> <p>c) Use the Diagnosing Abnormal States using LEDs above to resolve the state of that QS882A module to a normal state.</p> <p>d) If all the modules are displaying a normal state and a Power Minor is still being issued the Power Minor Relay should be replaced. The power Minor Relay is marked K2 and located closer to the front of the shelf in Figure 5-13.</p> <p>e) Replace the Socketed Relay with OmniOn Power Part Number 406789586.</p> <p>f) Confirm that the alarms have been successfully retired</p>		

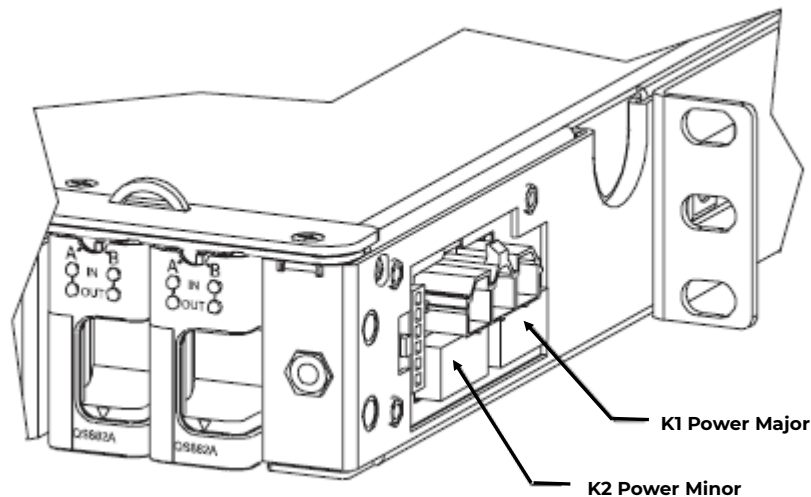

**Figure 5-13: Relay Identification for Replacement**

This page intentionally left blank

## 6 Electrical Interface Reference Information

### Shelf Electrical Interfaces

Interface	Cable Length (inches)	Connector Label	Comments
+/- 190V DC Input	12	P800	
-48V DC Output	24	P700	Use 8 AWG stranded THHN wire.
Alarm Output	24	P321	

### Connector Details

The following parts are used on QS800A wire sets. Choose the appropriate mating connector for your specific application.

Connector	Description	Manufacturer Part Number
P800	50-position plug assembly (1/26 side entry)	Cinch KS21997L1
P700	3-position receptacle	Molex Receptacle 42816-0312 with 42815-0031 (8 AWG wire)
P321	16-position receptacle	Molex Receptacle 39-01-2165 with 39-00-0059 sockets (24-18AWG wire)

### Connector Pinouts

#### P800

P800		
-190V Pin	+190V Pin	Pair
1	26	1
2	27	2
3	28	3
4	29	4
5	30	5
6	31	6
7	32	7
8	33	8
9	34	9
10	35	10
11	36	11
12	37	12
13	38	13
14	39	14
15	40	15
16	41	16
17	42	17
18	43	18
19	44	19
20	45	20

Pins 20-25 and 46-50 are not connected.

Mate for P800 can be constructed using AMP Kit part number 1-229913-1. This 50 pin "Cable to Cable Receptacle with Tapered Cover and Screw Kit" accepts 24 AWG solid or stranded wire. The cable housing should be dressed away from pins 1 and 26 with the bundle exiting over pins 25 and 50.

## Connector Pinouts (Continued)

### P700

P700		
Pin	With jumper in place (default)	With jumper removed
1	Not Used	No Connection
2	-48V	-48V
3	RTN / Frame Ground	RTN

To create a custom wire set that connects directly to the shelf, mate for P700 can be constructed using:

- Molex Mini-Fit SR. 3 position housing: 42816-0312
- Molex Mini-Fit SR 8 AWG contact 42815-0031
- 8 AWG stranded UL1028 MTW 600V wire

Our stock cable uses black for -48 and white for return

### P321

P321	
Pin	Function
1	Power Major Alarm NC
2	Power Major Alarm Common
3	Power Major Alarm NO
4	Power Minor Alarm NC
5	Power Minor Alarm Common
6	Power Minor Alarm NO
7-16	No Connection

Notes: Both alarms are fail-safe isolated Form C contact closures NC = Normally Closed, NO = Normally Open Use same ratings for relays as CPS4000 alarm relays

### Alternate Alarm Wire set

Alarm Output Connector	
Pin	Function
1	Power Major Alarm NC
2	Power Major Alarm Common
3	Power Major Alarm NO
4	Power Minor Alarm NC
5	Power Minor Alarm Common
6	Power Minor Alarm NO

Notes: Both alarms are fail-safe isolated Form C contact closures NC = Normally Closed, NO = Normally Open Use same ratings for relays as CPS4000 alarm relays

To create a custom wire set that connects directly to the shelf, mate for the Alarm Output Connector can be constructed using:

- AMP 6 Position Housing 1445022-6
- AMP Socket Contact 794606-1
- 22 AWG Stranded Wire



## 7 Reference Information

### CPS2500D Shelf

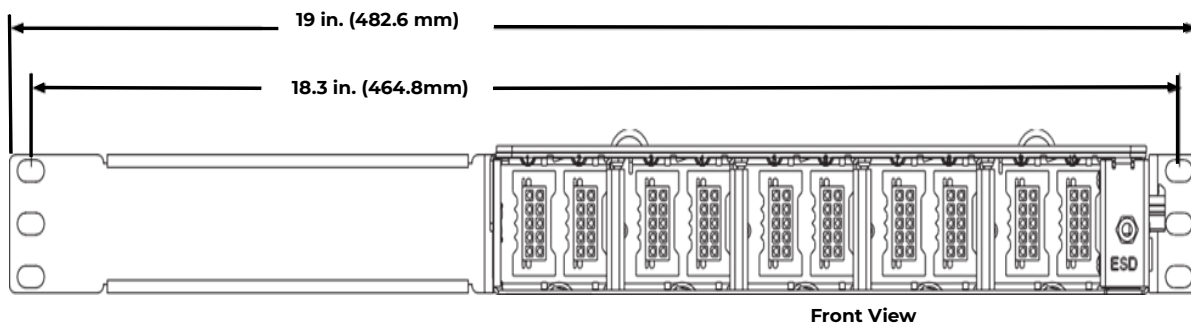
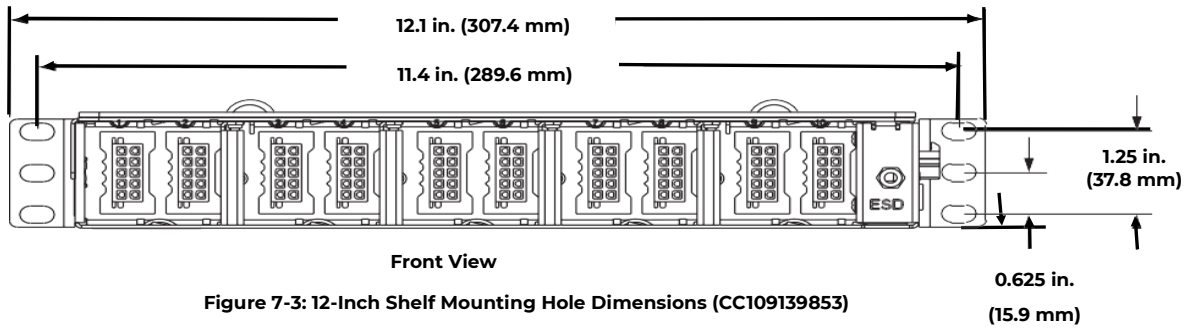
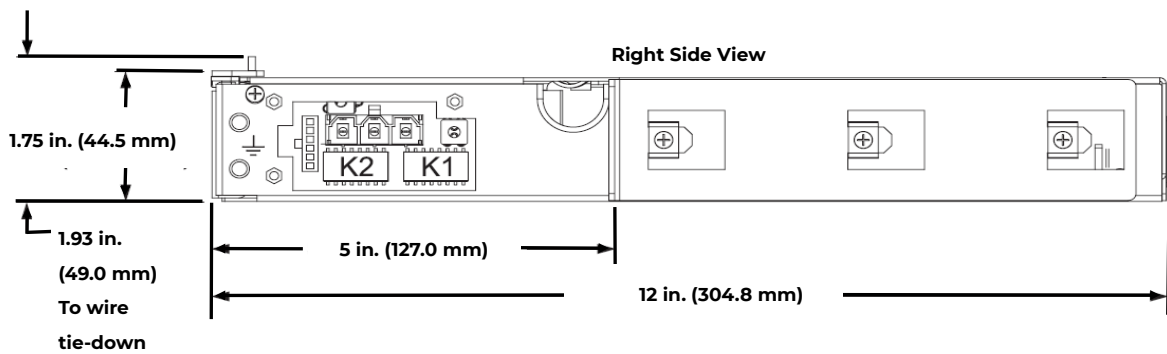
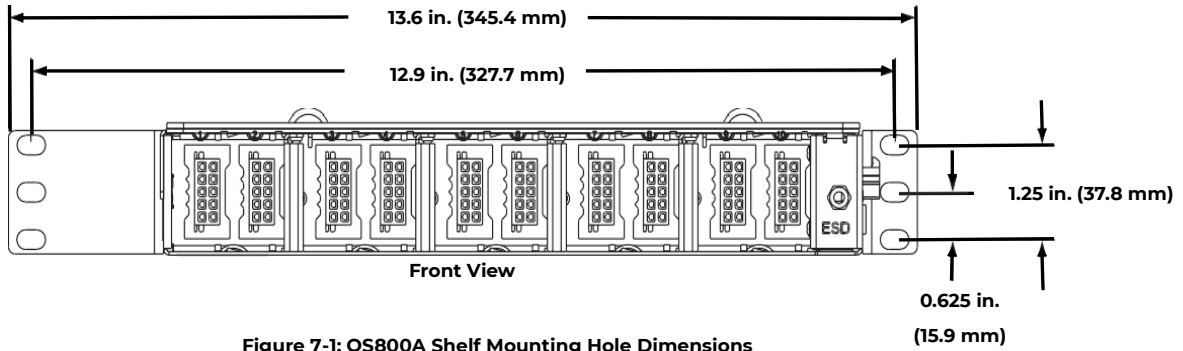

## 7 Reference Information (Continued)

### QS882A Converter

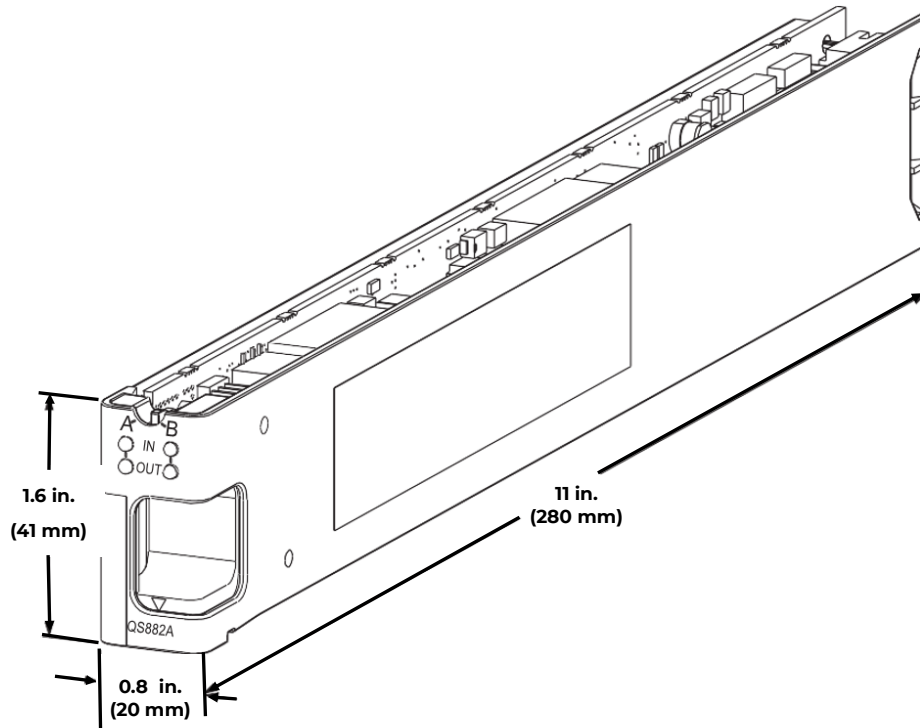
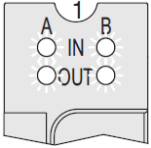
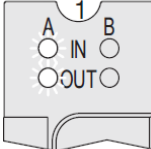
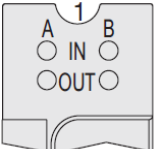
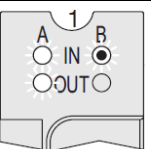
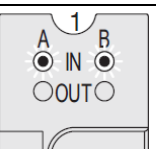
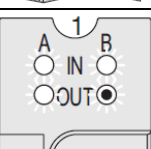
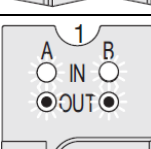
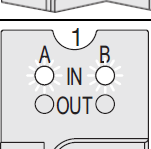

Figure 7-5: Q882A Size

## 7 Reference Information (Continued)

LED Indicators		Condition	Shelf Alarm
Green Green		Both circuits receiving input voltage within acceptable range with input current below maximum input value, and delivering acceptable output.	None
Green Green		Circuit A receiving input voltage within acceptable range with input current below maximum input value and delivering acceptable output. Circuit B has never received power.	None
		Neither circuit has received acceptable input voltage since insertion into powered shelf.	None
Green Green		Input voltage has been interrupted to circuit B. Occurs after circuit B has been powered acceptably.	MIN
Red		Input voltage has been interrupted to both circuits A and B. Occurs after both circuits have been powered acceptably.	MAJ
Green Green		Circuit B has internal failure but acceptable input power. Circuit A has acceptable input and output power.	MIN
Green Red		Both circuit A and circuit B have internal faults while input power is acceptable.	MAJ
Green OUT		Load power exceeds source power delivery capability. Both circuits in input limit mode.	MAJ

**Note:** Minor and Major alarms are mutually exclusive. Only one can be asserted at a time.

**Table 7-A: LED Truth Table**

This page intentionally left blank

## 8 Product Warranty

A. Seller warrants to Customer only, that:

1. As of the date title to Products passes, Seller will have the right to sell, transfer, and assign such Products and the title conveyed by Seller shall be good;
2. During the warranty period stated in Sub-Article B below, Seller's Manufactured Products (products manufactured by Seller), which have been paid for by Customer, will conform to industry standards and Seller's specifications and shall be free from material defects;
3. With respect to Vendor items (items not manufactured by Seller), Seller warrants that such Vendor items, which have been paid for by Customer, will be free from material defects for a period of sixty (60) days commencing from the date of shipment from Seller's facility.

B. The Warranty Period listed below is applicable to Seller's Manufactured Products furnished pursuant to this Agreement, commencing from date of shipment from Seller's facility, unless otherwise agreed to in writing:

### Warranty Period

Product Type	New Product	Repaired Product*
Central Office Power Equipment	24 Months	6 Months

\*The Warranty Period for a repaired Product or part thereof is six (6) months or, the remainder of the unexpired term of the new Product Warranty Period, whichever is longer.

- C. If, under normal and proper use during the applicable Warranty Period, a defect or nonconformity is identified in a Product and Customer notifies Seller in writing of such defect or nonconformity promptly after Customer discovers such defect or nonconformity, and follows Seller's instructions regarding return of defective or nonconforming Products, Seller shall, at its option attempt first to repair or replace such Product without charge at its facility or, if not feasible, provide a refund or credit based on the original purchase price and installation charges if installed by Seller. Where Seller has elected to repair a Seller's Manufactured Product (other than Cable and Wire Products) which has been installed by Seller and Seller ascertains that the Product is not readily returnable for repair, Seller will repair the Product at Customer's site. With respect to Cable and Wire Products manufactured by Seller which Seller elects to repair but which are not readily returnable for repair, whether or not installed by Seller, Seller at its option, may repair the cable and Wire Products at Customer's site.
- D. If Seller has elected to repair or replace a defective Product, Customer shall have the option of removing and reinstalling or having Seller remove and reinstall the defective or nonconforming Product. The cost of the removal and the reinstallation shall be borne by Customer. With respect to Cable and Wire Products, Customer has the further responsibility, at its expense, to make the Cable and Wire Products accessible for repair or replacement and to restore the site. Products returned for repair or replacement will be accepted by Seller only in accordance with its instructions and procedures for such returns. The transportation expense associated with returning such Product to Seller shall be borne by Customer. Seller shall pay the cost of transportation of the repaired or replacing Product to the destination designated by Customer.
- E. Except for batteries, the defective or nonconforming Products or parts which are replaced shall become Seller's property. Customer shall be solely responsible for the disposition of any batteries.
- F. If Seller determines that a Product for which warranty service is claimed is not defective or nonconforming, Customer shall pay Seller all costs of handling, inspecting, testing, and transportation and, if applicable, traveling and related expenses.

## 8 Product Warranty (Continued)

G. Seller makes no warranty with respect to defective conditions or nonconformities resulting from actions of anyone other than Seller or its subcontractors, caused by any of the following: modifications, misuse, neglect, accident, or abuse; improper wiring, repairing, splicing, alteration, installation, storage, or maintenance; use in a manner not in accordance with Seller's or Vendor's specifications or operating instructions, or failure of Customer to apply previously applicable Seller modifications and corrections. In addition, Seller makes no warranty with respect to Products which have had their serial numbers or month and year of manufacture removed, altered, or experimental products or prototypes or with respect to expendable items, including, without limitation, fuses, light bulbs, motor brushes, and the like. Seller's warranty does not extend to any system into which the Product is incorporated. This warranty applies to Customer only and may not be assigned or extended by Customer to any of its customers or other users of the Product.

THE FOREGOING WARRANTIES ARE EXCLUSIVE AND ARE IN LIEU OF ALL OTHER EXPRESS AND IMPLIED WARRANTIES, INCLUDING BUT NOT LIMITED TO WARRANTIES OF MERCHANTABILITY AND FITNESS FOR A PARTICULAR PURPOSE. CUSTOMER'S SOLE AND EXCLUSIVE REMEDY SHALL BE SELLER'S OBLIGATION TO REPAIR, REPLACE, CREDIT, OR REFUND AS SET FORTH ABOVE IN THIS WARRANTY.

## Appendix A Operating Temperature and Vertical Spacing

### Overview

The CPS2500 System has been designed for mounting in cabinets where -48Vdc is required. It is designed for use with other equipment that requires vertical airflow cooling. To operate in 65°C environments, 150 linear feet per minute (Lfm) airflow must be provided.

### Operating Temperature

75°C operation is possible with additional airflow. Confirmation testing is required.

## 9. Revision

Rev.	Description	Date Dept./Init.
2	Formatting issues only	
3	Added safety, grounding, jumper, and connector information Added QS800B shelf and 19-inch adapter bracket	
4	Rebranding	
2.2	Updated as per template	09/27/2021
2.3	Updated as per OmniOn template	11/29/2023

**OmniOn Power Inc.**

601 Shiloh Rd.  
Plano, TX USA

[omnionpower.com](http://omnionpower.com)

We reserve the right to make technical changes or modify the contents of this document without prior notice. OmniOn Power does not accept any responsibility for errors or lack of information in this document and makes no warranty with respect to and assumes no liability as a result of any use of information in this document.

We reserve all rights in this document and in the subject matter and illustrations contained therein. Any reproduction, disclosure to third parties or utilization of its contents – in whole or in parts – is forbidden without prior written consent of OmniOn Power. This document does not convey license to any patent or any intellectual property right. Copyright© 2023 OmniOn Power Inc. All rights reserved.