

QUICK START GUIDE

CC1600-SC55 Small Cell -48V Power Source

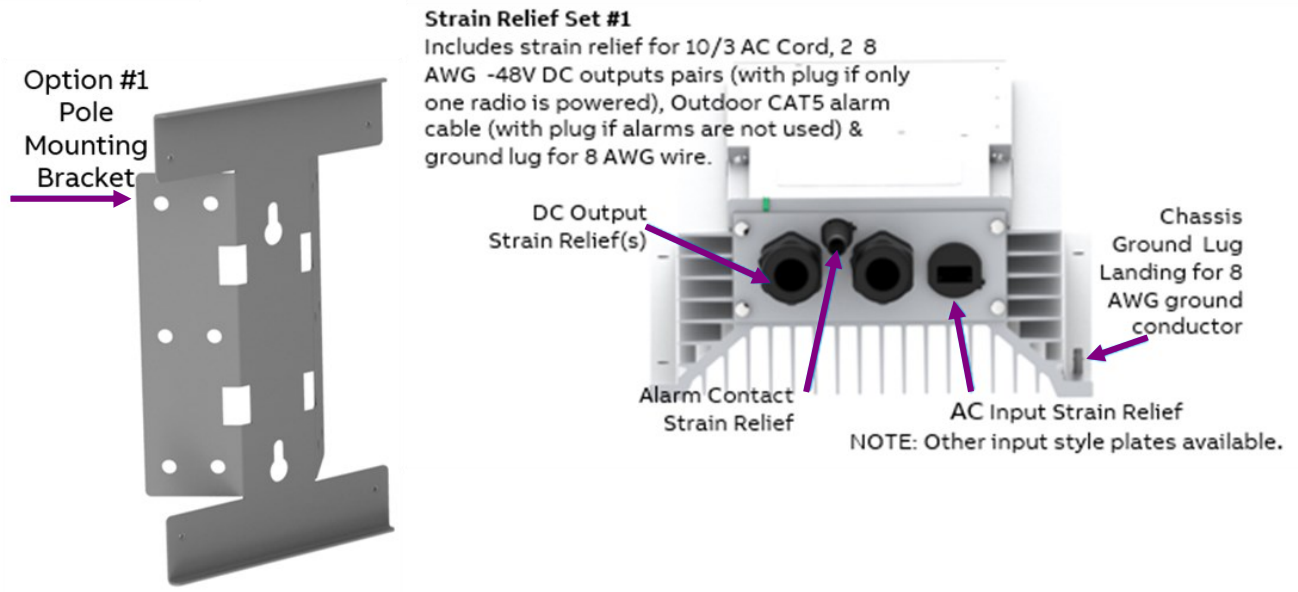
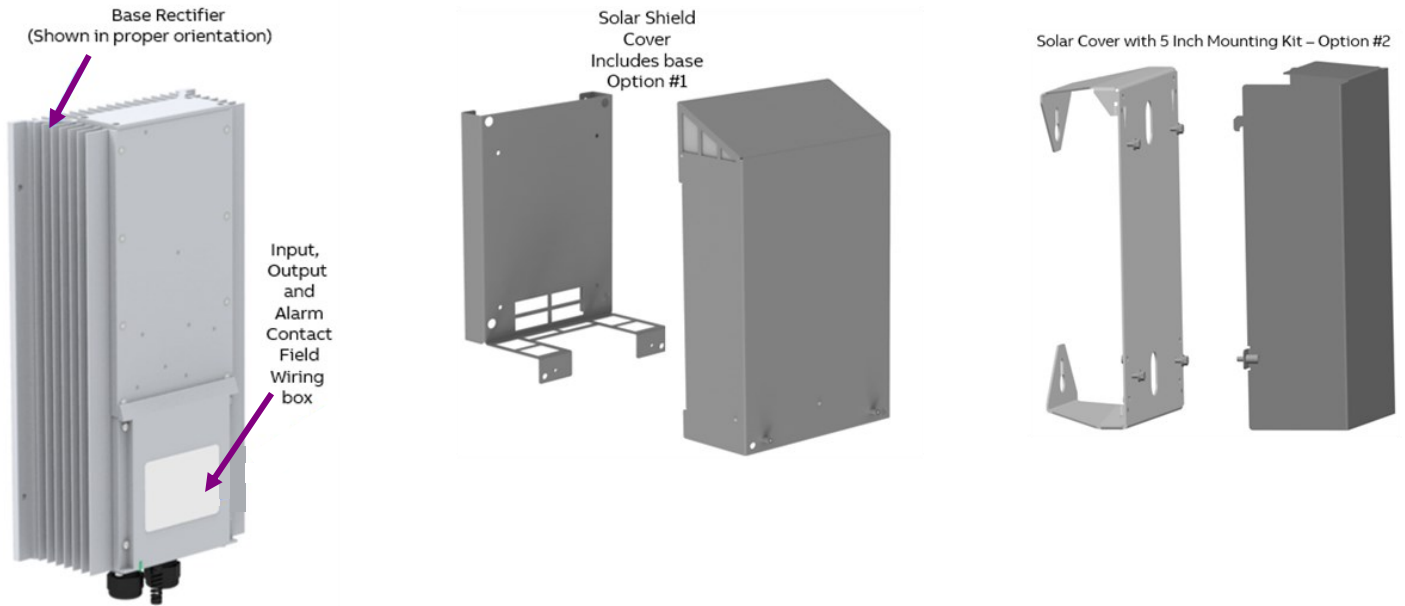

Contents

Important Safety Instructions	3
Precautions.....	4
Introduction.....	5
Installation	5
1. Prepare a Location and mounting option for the Small Cell -48V Power Source w/ Shield Base Option. 1.....	5
2. Mount the Solar Shield Base w/ Solar Shield Base Option 1	5
3. Prepare a Location & mounting for the Small Cell -48V Power Source w/ Five (5") Elevation Option. 2	7
4. Mount the Base Rectifier.....	8
5. Ground the Rectifier	8
6. Open the Field Wiring Compartment.....	8
7. Wire the DC Output with Panel Option #1.....	9
8. Wire the DC Output with Panel Option #2.....	10
9. Wire the Alarms	11
10. Wire the AC Input.....	11
11. Close the Field Wiring Compartment	12
12. Apply AC Power and Confirm -48V Power Delivery.....	13
13. Attach the Solar Shield Cover for Solar Option 1.....	13
14. Attach the Solar Shield Cover for Solar Option 2.....	14
 Information:	
Electrical Connections.....	14
LED States.....	14
Pole Mount Bracket Detail for Option 1	16
Pole Mount Bracket Detail for Option 2	17
 Parts List	18
Specifications & Application	18
Reference Documents.....	18

Important Safety Instructions

1. SAVE THESE INSTRUCTIONS – This document contains important safety and operating instructions for the Small Cell 48V Power Source.
2. Before using the Small Cell 48V Power Source, read all instructions and cautionary markings on the AC Panel Feeding the unit, the radio, and all other connected equipment.
3. Rules and Regulations - Follow all national and local rules and regulations when making field connections.
4. Field-wired Conductors - Follow all National Electric Code (NEC) and local rules and regulations.
 - a. Insulation rating: 90°C minimum; 105°C (minimum) if internal to enclosed equipment cabinets.
 - b. Size AC field-wired conductors with 75°C ampacity (NEC) equal to or greater than their panel board circuit breaker rating.
 - c. Size DC field-wired conductors with 90°C ampacity (NEC) equal to or greater than 30A .
5. AC input disconnect/protection - Provide accessible devices to remove input power in an emergency.
6. Compression Connectors
 - a. U. S. or Canada installations - use Listed/Certified compression connectors to terminate Listed/Certified field-wire conductors.
 - b. All installations - apply the appropriate connector to the correct size conductor as specified by the connector manufacturer, using only the connector manufacturer's recommended or approved tooling for that connector.
7. Electrical Connection Securing: Torque to the values specified on labels or in the product documentation.
8. Cable Dress - dress to avoid damage to the conductors and undue stress on the connectors. Always provide a drip loop to shed water off cables before they enter the strain reliefs.
9. Alarm Signals - Provide external current limiting protection. Rating–60V (125V for 125V charger), 0.5A unless otherwise noted.
10. Grounding - Connect the equipment chassis directly to ground.
11. This equipment is to be mounted directly and permanently above non-combustible surface, such as concrete or metal.
12. WARNING: Equipment is not designed to charge an external battery source.
13. WARNING: A battery can present a risk of electrical shock, burn from high short circuit current, fire or explosion from vented gases. Observe proper precautions.

Precautions

- Install, service, and operate equipment only by professional, skilled and qualified personnel who have the necessary knowledge and practical experience with electrical equipment and who understand the hazards that can arise when working on this type of equipment.
- Do not disconnect permanent bonding connections unless all power inputs are disconnected.
- Verify that equipment is properly safety earth grounded before connecting power. High leakage currents may be possible.
- Exercise care and follow all safety warnings and practices when servicing this equipment. Hazardous energy and voltages are present in the unit and on the interface cables and connectors that can shock or cause serious injury.
- Use safe lifting practices. The equipment is heavy. Lifting devices are recommended.
- Use the following precautions in addition to proper job training and safety procedures:
 - Use only properly insulated tools.
 - Remove all metallic objects (key chains, glasses, rings, watches, or other jewelry).
 - Follow Lock Out Tag Out (LOTO) procedures: customer specified, site specific, or general as appropriate. Disconnect all power input before servicing the equipment. Check for multiple power inputs.
 - Wear safety glasses.
 - Follow Personal Protective Equipment requirements: customer specified, site specific, or general as appropriate.
 - Test circuits before touching.
 - Be aware of potential hazards before servicing equipment.
 - Identify exposed hazardous electrical potentials on connectors, wiring, etc.
 - Avoid contacting circuits when removing or replacing covers;
 - Use a personal ESD strap when accessing or removing electronic components.
- Follow all warning and precautionary battery instructions, including proper replacement and disposal procedures, to minimize risk of injury.
- Personnel with electronic medical devices need to be aware that proximity to DC power and distribution systems can affect medical electronic devices, such as pacemakers. Effects decrease with distance.

Read and follow all safety statements, warnings, and precautions in this guide.

Introduction:

The Small Cell -48V Power Source provides -48Vdc power to next generation radios used in small cell sites. It delivers 1200 Watts of DC Power from 120Vac source, or 1600 Watts of DC power from a 208-240Vac source.

Basic Features:

One DC output can be wired to 2 different devices. The positive voltage is referenced to ground. The output is -48V nominal. It can be powered off of either 120Vac or 208-240Vac with operational parameters as shown here:

Input: 11.5 A @ 120Vac, Output: 21.8A @55Vdc / 1200 W Maximum.

Installation

Regulations, standards, site engineering instructions, MOPs, etc. take precedence over these general installation instructions.

Tools required:

<ul style="list-style-type: none"> • Steel toed safety shoes • Wire cutters, strippers, Termination & Channel Lock 	<ul style="list-style-type: none"> • Torque wrench - 0-65 in-lb (0-10 Nm) and 40 ft-lbs • Volt Meter for Lock-Out Tag-Out procedures. 	<ul style="list-style-type: none"> • Sockets - as needed for mounting hardware • Screwdrivers - #2 pozi drive screwdriver. Flat and Torx bit set
--	---	--

Step 1 – Prepare a Location and mounting option for the Small Cell -48V Power Source w/ Shield Base Opt. 1

The unit can mount to a pole, to a wall with solar shield, or to location shaded from the sun. Step 1 is preparing the foundation to receive either a solar shield, or the bare Small Cell -48V Power source.

When choosing a location for the Small Cell -48V Power Source, please keep in mind:

1. The rectifier must be mounted in “portrait” orientation so that air can flow vertically by natural convection.
2. Leave 3 inches above and below the unit to allow air to feed the fins and exit from the fins.
3. If the mounting location has sun exposure, a solar shield or cabinet must be used to protect the unit from direct sun.
4. Mount the unit above the flood line. Weep holes to equalize pressure and drain any water/condensate that may enter.
5. Orient the wiring entrance toward the ground and provide drip loops to shed any water running down the jacket.

p/o Step 1 – Pole Locations For use with Solar Shield Option 1

- Remove the pole mount bracket from the packaging.
- Select an elevation and orientation on the pole. Note: Wires must dress out of the bottom of the unit when installed. Use the bracket as a template to locate holes. 2 primary holes are on 10 inch centers.
- Use 1/2 inch diameter hardware, 1.25 inch wide straps or 1/2 inch threaded rod to attach the pole mount bracket to the pole. Torque lag bolts as specified on the bolt corresponding to the pilot hole and material of the pole. Torque hdwr on 1/2 inch threaded rod to 38 ft-lbs.

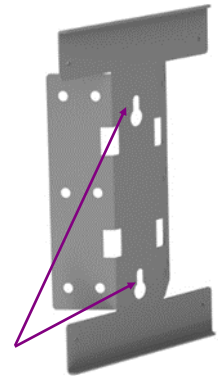

p/o Step 1 – Wall Locations For Use with Solar Shield Option 1

- Remove the Solar Shield Cover and Solar Shield Base from the packaging. Put the cover aside, or back into the packaging, to save for a later step.
- Select a location for the Small Cell Power Source. Location should be above highest recorded flood level. Note: Bracket must be mounted in “Portrait” orientation with the shelf on the bottom edge, as shown here.
- Drill holes to accept four 1/4” fasteners. Use the Solar Shield Base as a template. Vertical hole centers are 15.6 inches apart. Horizontal hole centers are 10.4 inches apart.



p/o Step 1 Wall Mount Shaded Locations (With Shield Base Option 1)

- Remove the Base Rectifier from the packaging.
- Select a location for the Small Cell Power Source. Location should be above highest recorded flood level. Note: Unit must be mounted in “Portrait” orientation with the wires at the bottom.
- Drill holes to accept four 1/4” fasteners. Use the Base Rectifier as a template. Vertical hole centers are 12 inches apart. Horizontal hole centers are 8.87 (8 and 7/8) inches apart.

Step 2 – Mount the Solar Shield Base w/ Solar Shield Base Option 1

If a Solar Shield is called for, mount the Solar Shield Base to the four 1/4-20 holes in the pole mount bracket, or the prepared holes in the wall prepared in Step 1. Torque bolts as recommended by the wall anchor manufacturer, or to 65 in-lbs. if using the pole mount bracket.

CAUTION: Use safe lifting practices. Lifting devices are recommended. Steel toed shoes required.

The wall and fasteners must safely support 90 lbs. (3 times the weight of the completed assembly).

Mount with 4 fasteners rated for at least 50 lbs. each

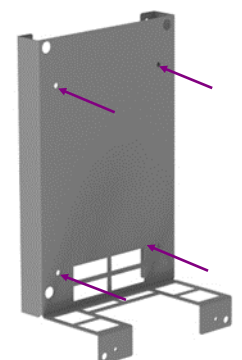

Step 3 – Prepare a Location & mounting for the Small Cell -48V Power Source w/Five (5”) Elevation Option. 2

The unit can mount to a pole, to a wall with solar shield, or to location shaded from the sun. Step 3 is preparing the foundation to receive either a solar shield, or the bare Small Cell -48V Power source.

When choosing a location for the Small Cell -48V Power Source, please keep in mind:

1. The rectifier must be mounted in “portrait” orientation so that air can flow vertically by natural convection.
2. Leave 3 inches above and below the unit to allow air to feed the fins and exit from the fins.
3. If the mounting location has sun exposure, a solar shield or cabinet must be used to protect the unit from direct sun.
4. Mount the unit above the flood line. Weep holes to equalize pressure and drain any water/condensate that may enter.
5. Orient the wiring entrance toward the ground and provide drip loops to shed any water running down the jacket.

p/o Pole or Wall Locations For Five (5”) Elevation Bracket (For Use with Solar Shield Option 2)

- A. Remove the 5” Elevation bracket from the packaging.
- B. Select an elevation and orientation on the pole. Note: Wires must dress out of the bottom of the unit when installed. Use the bracket as a template to locate holes. 2 primary holes are on 13” inch centers.
- C. Use 1/2 inch diameter hardware or 1/2 inch threaded rod to attach the pole mount bracket to the pole. Torque lag bolts as specified on the bolt corresponding to the pilot hole and material of the pole. Torque hardware on 1/2 inch threaded rod to 38 ft-lbs.

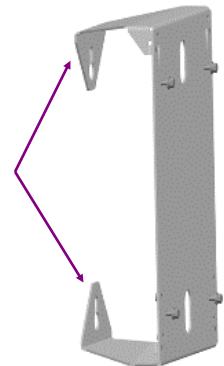

Wall or Pole Mount (in Shaded Location) Five (5”) Elevation Bracket Option #2

- A. Follow Steps A and B from above.
- B. Use 1/2 inch diameter hardware or 1/2 inch threaded rod to attach the pole mount bracket to the pole. Torque lag bolts as specified on the bolt corresponding to the pilot hole and material of the pole. Torque hardware on 1/2 inch threaded rod to 38 ft-lbs.

Step 4 – Mount the Base Rectifier

CAUTION: Use safe lifting practices. The Base Rectifier is heavy at 25 lbs. Steel toed shoes are required. Lifting devices are recommended for elevated applications.

1. If mounting to a wall, hold the rectifier so that the holes line up. If using the Solar Shield kit, place the rectifier on the “shelf of the solar shield base” so that the 4 holes for 1/4 inch hardware line up.
2. Use a 1/4 inch fastener to secure the Base Rectifier to the Solar Shield Wall or Base.
3. Torque each of the 4 bolts as recommended by the wall anchor manufacturer, or to 65 in-lbs. if using the Solar Shield.



Step 5 – Ground the Rectifier

There are #10-32 studs on 5/8 centers on the lower right corner of the rectifier. Use this location to provide external grounding as required by code or network standard. 8 AWG minimum recommended ground wire.

Torque each nut to 26 in-lbs.

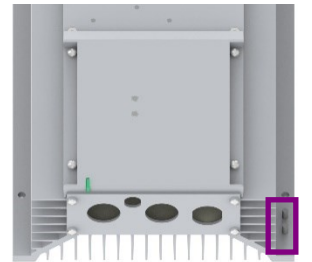

Step 6 – Open the Field Wiring Compartment

The field wiring compartment is located on the lower third of the unit. The front cover is secured by 4 captive screws. The bottom cover that provides strain relief is also secured by 4 captive screws.

1. Use a slotted screwdriver, or Torx security pin bit, to loosen each of the 4 captive screws on the front face of the wiring cover.
2. Once all four screws are loose, remove the wiring cover. Wiring chamber will look like this.
3. Use a slotted screwdriver, or Torx security pin bit, to loosen each of the 4 captive screws on the face of the bottom cover.
4. Once all four screws are loose, remove the bottom cover that provides strain relief. The Field Wiring Compartment should now look like figure below.

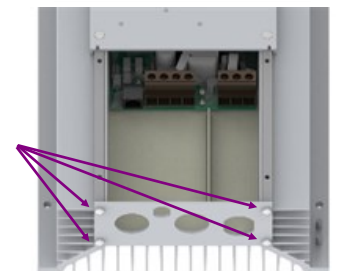
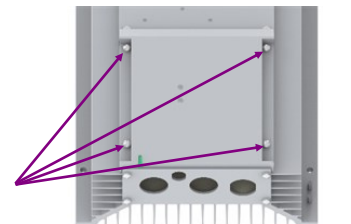

Step 7 – Wire the DC Output Option #1

Two DC Output, One AC Input, Alarms

This rectifier configuration will accept up to 2 pairs of 8 AWG Wire in the terminal block located on the left side of the wiring space. Select a wire and jacket suitable for the application. The DC strain relief hole is a 3/4" trade size hole. If the supplied strain relief does not work with the wire selected, use a strain relief that does.

1. Run the DC output cable through the strain relief fitting, left hole on the strain relief cover .
2. Strip the outer jacket to reveal 2 inches of inner conductor.
3. If there are more than 2 conductors in the jacket, apply 1 inch of heat shrink tubing to the conductor that will be unused, leaving 1/2 inch of free tubing past the end of the conductor to assure that that conductor will never be energized.
4. Strip the inner jacket off the two conductors to expose 7/16 inches (11mm) of bare conductor.
5. Connect the first pair of the wires to the first set of + and -48V terminals, toward the left end of the terminal block. One wire carries +. The other carries -48V. See Information Table on sheet 9
6. Torque each screw compression fitting to 12 in-lbs. using a flat bladed screw driver.3e, or #2 pozi drive screwdriver.
7. Pull wire to verify.
8. Repeat 1-7 for the second output using the second strain relief and strain relief hole if desired.

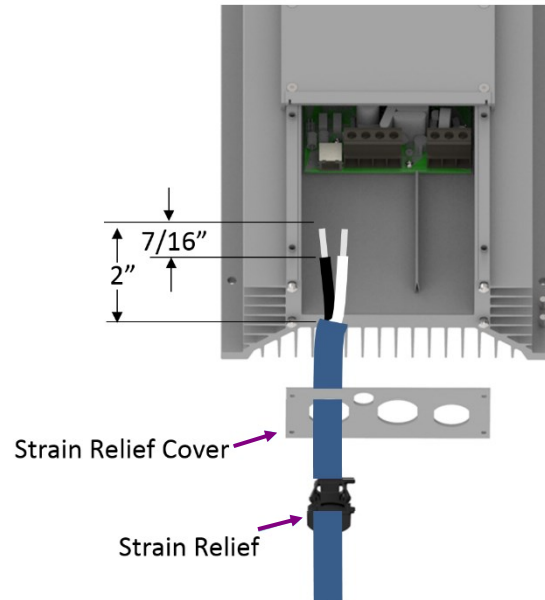

View Shown with DC Output Panel Option #1

Step 8 – Wire the DC Output Option #2

Three DC Output, One AC Input, Alarms

For Dual load configurations up to two (2) 8 AWG wires can be used for the first and second strain relief and terminal block positions. When using multiple loads, up to two 16 AWG wires can be combined into a single ferrule lug and placed into each of the (+) and (-) terminal block positions. Add a piece of shrink tubing to cover the wire crimp connections. Select a wire and jacket suitable for the application. The DC strain relief holes are a 3/4" trade size hole. If the supplied strain relief does not work with the wire selected, use a strain relief that does.

1. Run the DC output cable through the strain relief fitting, left hole on the strain relief cover .
2. Strip the outer jacket to reveal 2 inches of inner conductor.
3. If there are more than 2 conductors in the jacket, apply 1 inch of heat shrink tubing to the conductor that will be unused, leaving 1/2 inch of free tubing past the end of the conductor to assure that that conductor will never be energized.
4. Strip the inner jacket off the two conductors to expose 7/16 inches (11mm) of bare conductor.
5. Connect the first pair of the wires to the first set of + and -48V terminals, toward the left end of the terminal block. One wire carries +. The other carries -48V. See Information Table on sheet 10.
6. Torque each screw compression fitting to 12 in-lbs. using a flat bladed screw driver, or #2 pozi drive screwdriver.
7. Pull wire to verify.
8. Repeat 1-7 for the second and third output using the second and third strain reliefs and strain relief holes if desired.

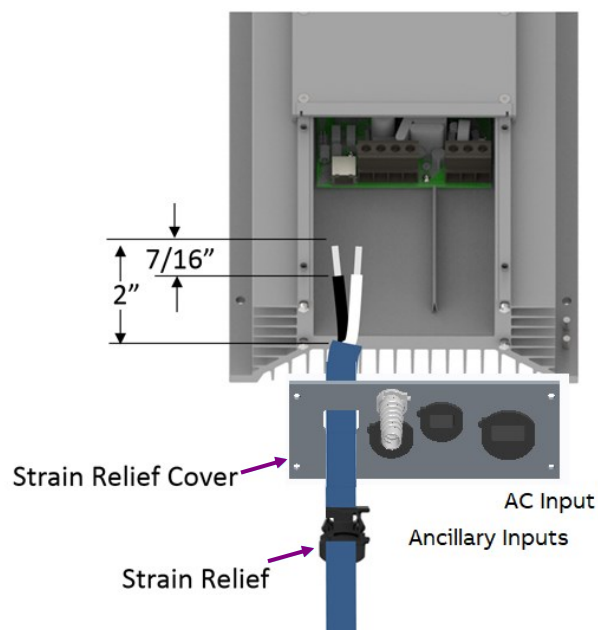

View shown with DC Output Panel Option #2

Step 9 – Wire the Alarms

The Small Cell -48V Power Source provides two optional alarm contact closures via an RJ-45 Jack and outdoor rated CAT-5 cable. See Information Table on Sheet 9.

1. Plug a shielded outdoor rated CAT-5 cable terminated with a shielded RJ-45 termination into the alarm connector on the PWB.
2. Run the other end of the wire through the smallest hole in the strain relief.
3. Terminate the CAT-5 cable with an RJ-45 connector.
4. Pull wire to verify that the connection is latched.

Note: The shield in this cable is to be terminated to ground at both ends. The ground termination on this end of the cable is made through the shell. The RJ-45 connector used should have the shield terminated to a shell that is like this one.

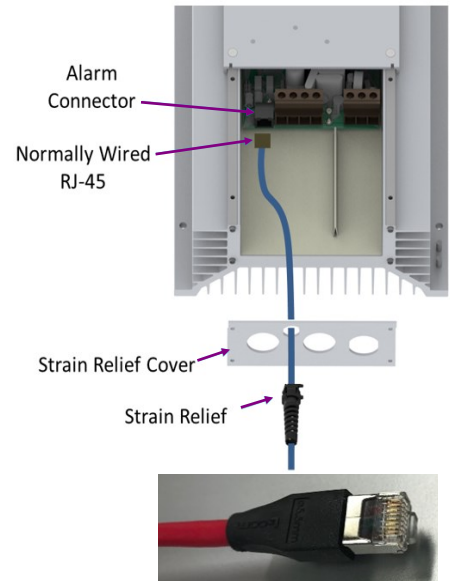

View Above shown using DC Output Option #1

Step 10 – Wire the AC Input

DANGER: Shock Hazard – Turn OFF and lock-out tag-out the AC source before making AC connections.

When connecting to AC mains, follow all local and national wiring rules.

CAUTION: Ensure that wires do not come in contact with sharp or rough surfaces that may damage insulation and cause a short circuit.

Verify all AC breakers are off!

The rectifier is designed for 10 AWG 3 conductor outdoor rated cable to be terminated in the terminal block located on the right side of the wiring space. Select a wire and jacket suitable for the application. Note: 15A or 20A circuit protection is required.

1. Run the AC input cable through the strain relief fitting, lower right hole on the strain relief cover.
2. Strip the outer jacket to reveal 2 inches of inner conductor.
3. Strip the inner jacket off each of the 3 conductors to expose 7/16 inches (11mm) of bare conductor.
4. Connect the ground wire first toward the left end of the terminal block. See Information Table on Sheet 9.
5. Torque the screw compression fitting to 12 in-lbs. using a flat bladed screw driver, or #2 pozi drive screwdriver.
6. Pull wire to verify.
7. Connect the Line 1 wire to the middle position of the terminal block. See Information Table on Sheet 9.
8. Torque the screw compression fitting to 12 in-lbs. using a flat bladed screw driver, or #2 pozi drive screwdriver.
9. Pull wire to verify.
10. Connect the line 2 or neutral conductor to the right end of the terminal block. See Information Table on Sheet 9.
11. Torque the screw compression fitting to 12 in-lbs. using a flat bladed screw driver, or #2 pozi drive screwdriver.
12. Pull wire to verify.

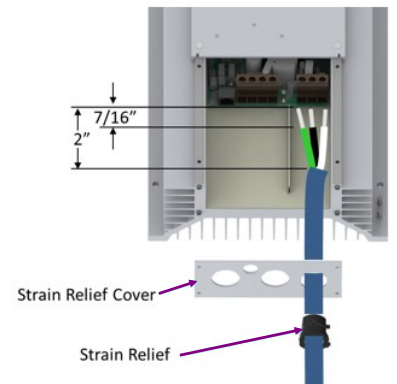

View Shown with DC Output Option #1

Step 11 – Close the Field Wiring Compartment

The field wiring compartment is closed in two steps: A) Complete the wire dress, strain relief and secure the bottom cover, and B) Close the front cover, making sure to establish separate compartment for the AC and DC wiring. Strain reliefs provided may be different by application.

Step 11A

1. Position the bottom cover on the chassis.
2. Use a flat bladed screw driver , or #2 pozi drive screwdriver, to secure all 4 captive screws.
3. Torque to 13 in-lbs.
4. Pull the leftmost DC cable out through the strain relief hole until it runs straight from the terminal block to the strain relief hole.
5. Secure the strain relief fitting in the hole on the bottom cover, using channel lock for snap in type strain relief as needed.
6. Again, pull the leftmost DC cable out through the strain relief hole until it runs straight from the terminal block to the strain relief hole.
7. Dress the wire with a drip loop and visibly relaxed region outside the unit.
8. Strain relieve the external wire to the environment to maintain this relaxed region even under load.
9. If used, pull the second DC cable out through the strain relief hole until it runs straight from the terminal block to the strain relief hole.
10. Secure the strain relief fitting in the hole on the bottom cover using channel lock for snap in type strain relief as needed.
11. Again, pull the 2nd DC cable out through the strain relief hole until it runs straight from the terminal block to the strain relief hole.
12. Dress the wire with a drip loop and visibly relaxed region outside the unit.
13. Strain relieve the external wire to the environment to maintain this relaxed region even under load.
14. Pull the AC cable out through the strain relief hole until it runs straight from the terminal block to the strain relief hole.
15. Secure the strain relief fitting in the hole on the bottom cover by compressing and inserting from the outside. Use a Channel Lock plier if mechanical assistance is needed.
16. Dress the wire with a drip loop and visibly relaxed region outside the unit.
17. Strain relieve the external wire to the environment to maintain this relaxed region even under load.
18. If used, pull the CAT-5 cable out through the strain relief hole until it runs straight from the RJ-45 to the strain relief hole.
19. Secure the strain relief fitting in the hole on the bottom cover by compressing and inserting from the outside.
20. Dress the wire with a drip loop and visibly relaxed region outside the unit.
21. Strain relieve the external wire to the environment to maintain this relaxed region even under load.

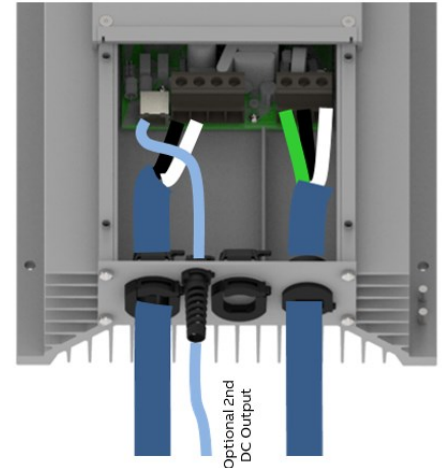

View above shown with DC panel option #1

1. Drip Loop dress and strain relief shall be provided for each cable exiting the rectifier.

Step 11B

1. Inspect to see that the separation between the AC and DC compartments is clear of wires from the circuit card all the way to the bottom cover.
2. Orient the cover with the LED showing in the lower left corner when viewed from the front.
3. Gently push the cover on until each of the tails of the captive screws is captured in the pilot holes.
4. Hand tighten the 4 captive screws, making sure there is no undue force as would be encountered if a wire were crossing from the AC compartment the DC compartment underneath the cover.
5. Torque each of the 4 captive screws to 13 in-lbs.

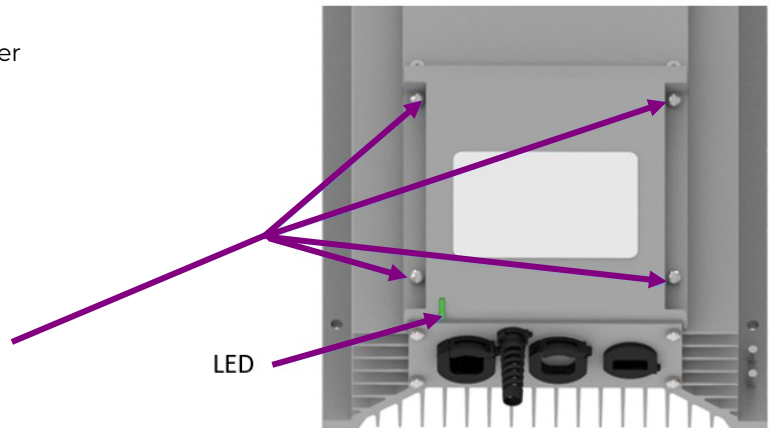

Step 12 – Apply AC Power and Confirm -48V Power Delivery

1. Terminate, insulate or protect the far end of the DC cables, as these will be energized when AC is applied.
2. Return to the AC panel feeding the unit.
3. Unlock the panel.
4. Energize the panel. (120Vac = 1200W max capacity; 240Vac = 1600W max capacity. 15A or 20A circuit protection is required.)
5. Turn on the circuit breaker feeding the Small Cell -48V Power Source.
6. Observe the LED illuminates green, indicating that DC is present on the output terminations.
7. Confirm that DC is present on the outputs by observing a signal from the radio(s).
8. Test the alarm contacts by cycling the AC to off. Observe that both alarms are active when no AC is present.

Step 13 – Attach the Solar Shield Cover for Solar Option 1

1. Assemble the Solar Shield Cover to the Base, enclosing the rectifier.
2. Secure the Solar Shield Cover using the two captive screws toward the lower edge of the unit.
3. Torque to 26 in-lbs.

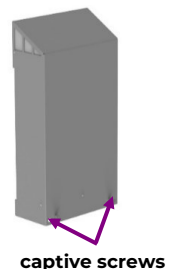

Step 14 – Attach the Solar Shield Cover for Solar Option 2

- A. Remove the Solar Shield Cover from the packaging.
- B. With the 5" Elevation bracket mounted in the previous setup, take the Solar Shield Cover and align the two top mounting hooks with the slots cut near the top corners of the mounting bracket.
- C. With the Solar Shield Cover held in place by the top latches, screw the bottom two (2) fasteners into the mounting bracket. Torque

Solar Cover with 5 Inch Mounting Kit – Option #2
Hook Latches and Solar Cover Mounting Screws

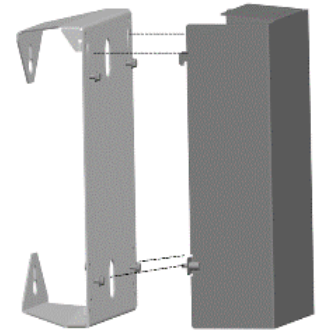

Information – Electrical Connections

Alarm Closure pin definitions for isolated contact closures (relays rated at 60Vdc and 0.5A with 3 to 5 ms switching times. Note: Shell of RJ-45 connector must be shielded and grounded at both ends.)

Pin #	Signal	Notes
1-4	N/C	
5	Comm	
6	RFA	Open on Alarm indicating rectifier failure.
7	Comm	
8	ACF	Open on Alarm indicating AC failure. Must be fast as radio must resolve and relay ACF as distinct from RFA in holdover window.

DC Output Terminal Block

Pin	1	2	3	4
Potential	RTN	-48V	RTN	-48V

Note: The outputs are common and electrically protected from short circuit. Maximum current delivered is limited. When the output is short circuited, the unit will cycle on and off with a interval of about 14 seconds. Short circuit hiccup is disabled for the first 20 seconds after start up to support the inrush requirements of the load.

AC Input Terminal Block

Pin	1	2	3
Potential	Ground	Line 1	Line 2/Neutral

Information – LED States

State	State Description	LED Color/State	Customer Action
1	No AC Input	Dark	Restore AC
2	Rectifier FAULT asserted	Red	Replace the CC1600-SC55 Unit*
3	DC output < 38V	Yellow	Replace Radio or Repair wiring to radio. The Rectifier is still good.
4	DC Output >38V	Green	Good

*Unit Replacement

If the unit has been determined to be in state #2 replace the unit. Replacing the unit requires removal of all wiring, using Lock-Out Tag-Out procedures, before the existing unit is removed.

Information – Lifting the Unit

The rectifier assembly is less than 80 lbs. and should have two installers to place the unit into position to the pole or wall mounting bracket.

Information – External Icing

When external icing affects the access to the four hardware screws a plastic or rubber hammer can be used to break the ICE to remove the securing screws.

Information – for Retrofit Applications

1. Remove the solar shield if applicable.
2. Turn off the power feeding the unit following Lock-Out Tag-Out procedures.
3. Remove the ACCESS cover and disconnect wiring.
4. Secure all wiring.
5. Remove hardware holding the rectifier in position by removing the four hardware screws.
6. Two installers shall remove the wall mounted or pole mounted unit.
7. Install the retrofit unit and secure with the appropriate hardware.
8. Install the electrical and dc output following removal using the installation procedure in reverse.
9. Close all openings and power the input and verify the LED is now green.
10. Close all openings and secure the access cover.
11. Replace the solar shield.

Information – Touch Up Paint

Should any part of the unit coating be damaged, repaint using:

LVP Powder and Paints

RAL7035 Touch Up Paint – Light Grey – 12 oz Spray Can.

<https://www.lowvolumepowder.com/RAL-7035-12-Oz-Touch-Up-Paint>

Information – Pole Mount Bracket Detail Drawing – Mounting Option #1

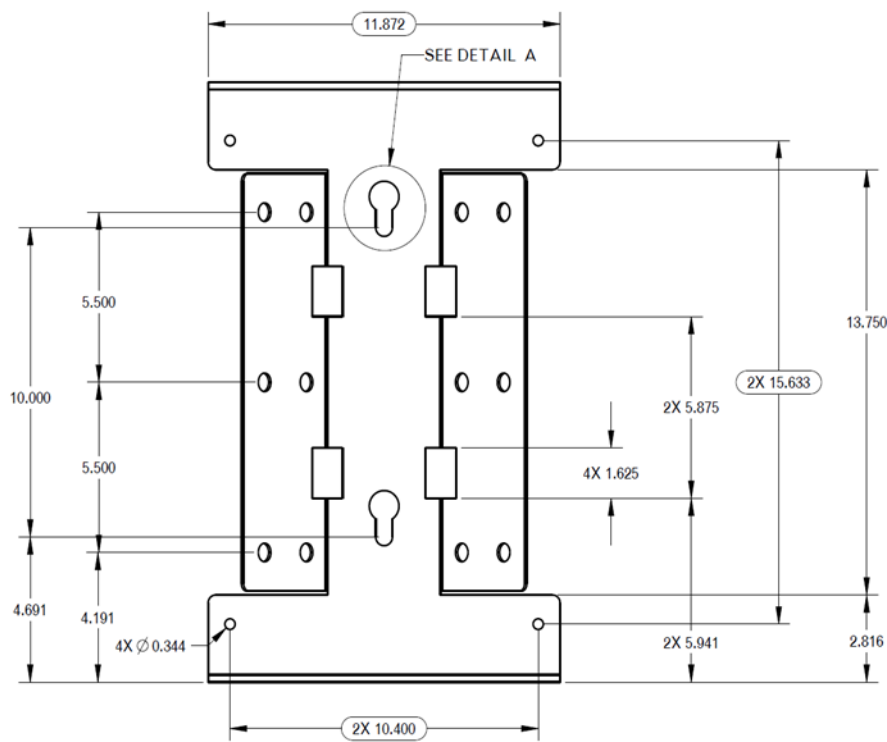
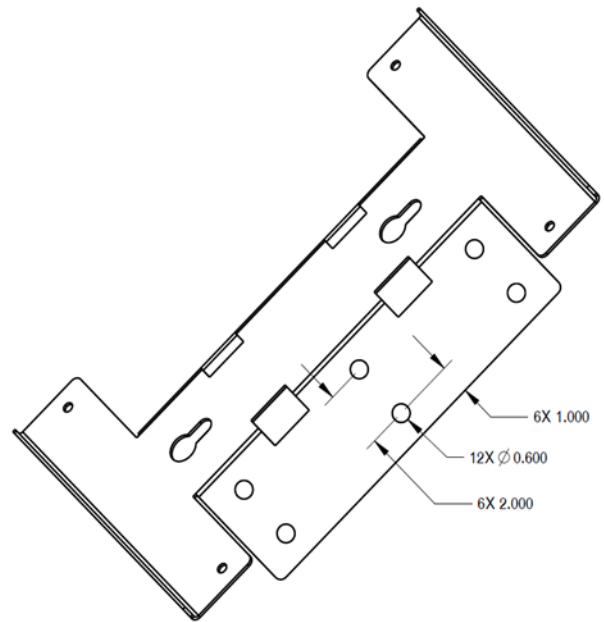
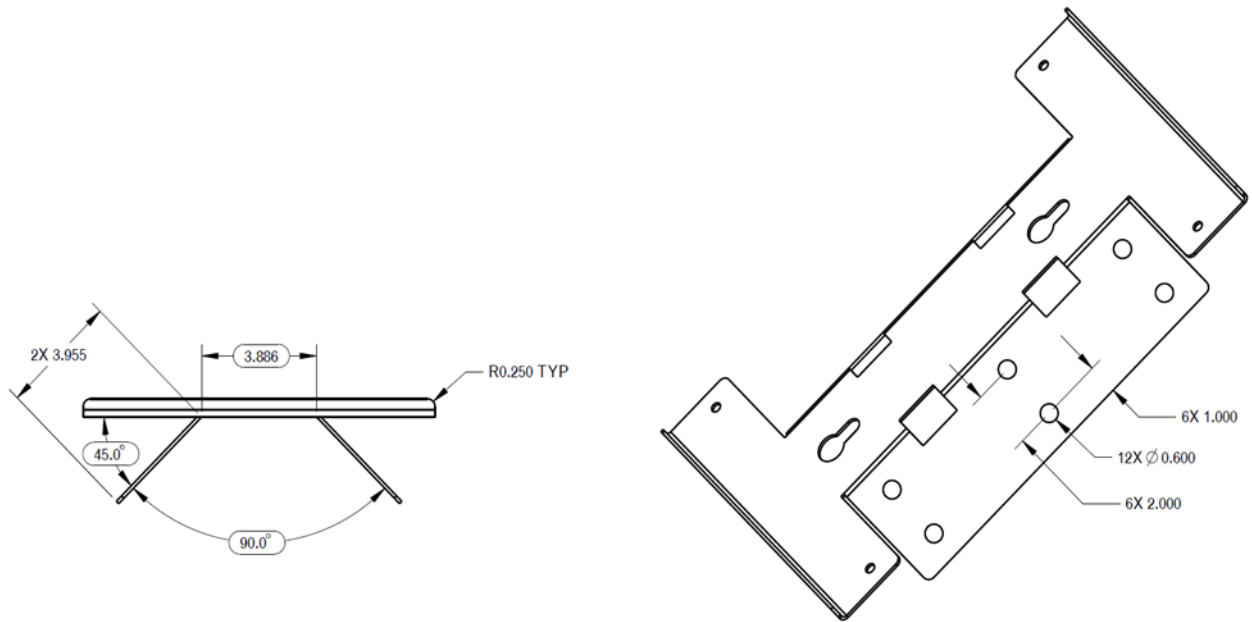

FRONT VIEW

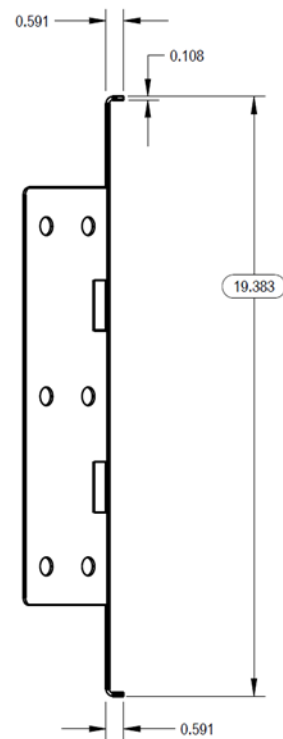

SIDE VIEW

Part List

Small Cell -48V Power Source Complete Kits Contain the Rectifier		
Ordering Code	Description	Application
1600131299A	Base Rectifier w/ Strain Relief	
1600183819A	Solar Shield Kit	
1600183817A	Pole Mount Kit	
Additional Accessories (Mounting Hardware, Filters, etc.)		
Ordering Code	Description	Application

Specifications and Application

- The AC input port of this device meets GR-1089 Table 4-2 First Level Lightning Surge test #21 (6kV, 3kA) without external surge protection device (SPD). In regions that experience consistently higher lightning activity, consider adding an external Surge Protective Device (SPD) consistent with region specific, and network specific, best standard practice.
- Equipment Safety is Approved to UL6950-22 Equipment to be Installed Outdoors in environments with ambient temperature up to 46°C.
- Equipment and subassembly ports:
 1. are suitable for connection to intra-building or unexposed wiring or cabling;
 2. can be connected to shielded intra-building cabling grounded at both ends.
- Grounding / Bonding Network – Connect to an Isolated Ground Plane (Isolated Bonding Network) or an Integrated Ground Plane (Mesh-Bonding Network or Common Bonding Network).
- Installation Environment - Install where NEC applies.

Reference Documents

Notes:

Change History (excludes grammar & clarifications)

Revision	Date	Description of the change
4.0	07-07-2023	Updated as per ABB template
4.1	09-11-2023	Updated as per OmniOn template

OmniOn Power Inc.

601 Shiloh Rd.
Plano, TX USA

omnionpower.com

We reserve the right to make technical changes or modify the contents of this document without prior notice. OmniOn Power does not accept any responsibility for errors or lack of information in this document and makes no warranty with respect to and assumes no liability as a result of any use of information in this document.

Page 21

© 2023 OmniOn Power Inc. All rights reserved.

We reserve all rights in this document and in the subject matter and illustrations contained therein. Any reproduction, disclosure to third parties or utilization of its contents – in whole or in parts – is forbidden without prior written consent of OmniOn Power. This document does not convey license to any patent or any intellectual property right. Copyright© 2023 OmniOn Power Inc. All rights reserved.

CC1600SC55_QSG

Rev. 4.1